

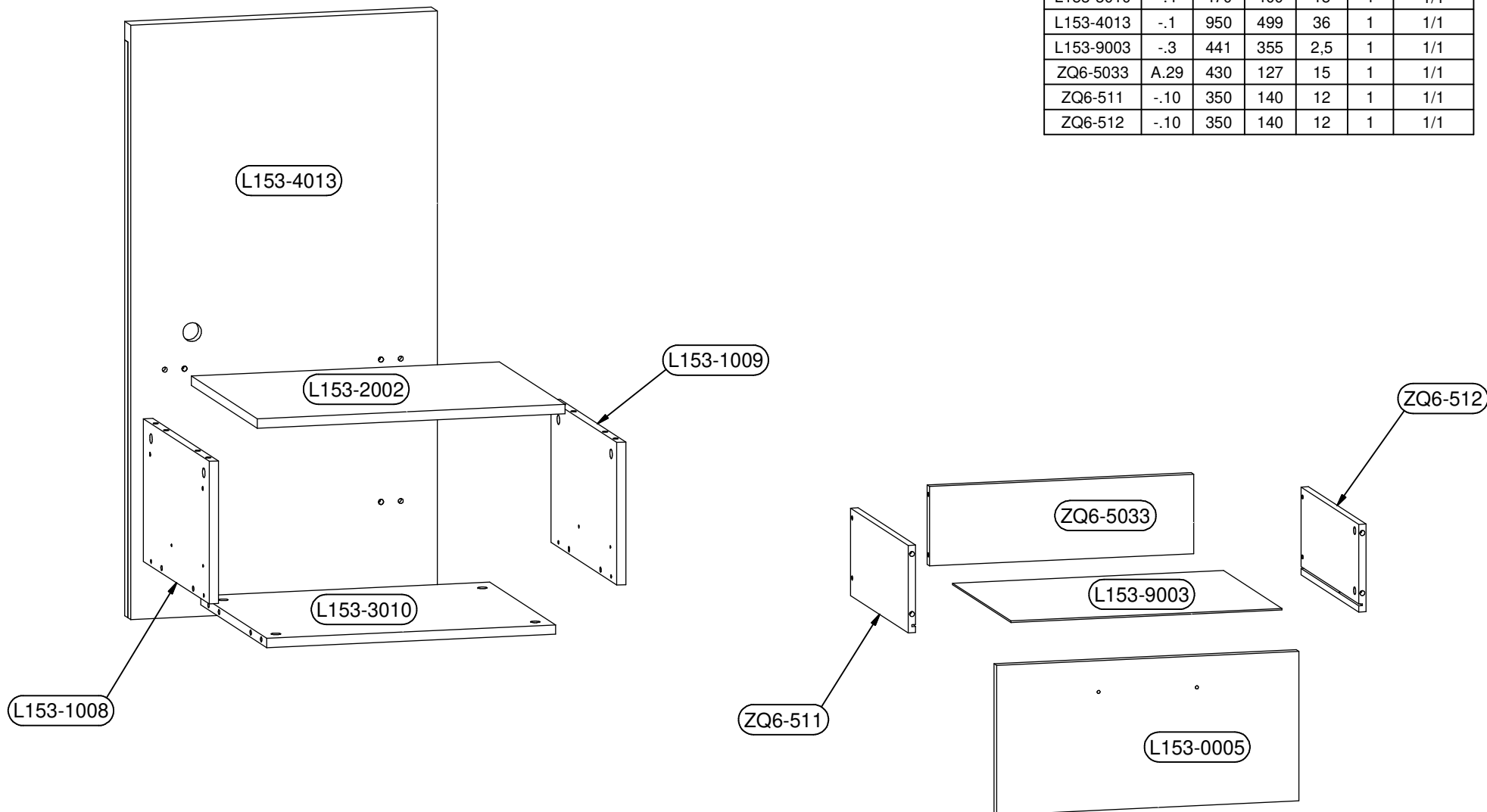

B1	B2	C1	C2	C3	C4	D
L153-0005	-.5	492	239	16	1	1/1
L153-1008	-.4	228	400	15	1	1/1
L153-1009	-.1	228	400	15	1	1/1
L153-2002	-.4	501	400	15	1	1/1
L153-3010	-.4	470	400	15	1	1/1
L153-4013	-.1	950	499	36	1	1/1
L153-9003	-.3	441	355	2,5	1	1/1
ZQ6-5033	A.29	430	127	15	1	1/1
ZQ6-511	-.10	350	140	12	1	1/1
ZQ6-512	-.10	350	140	12	1	1/1

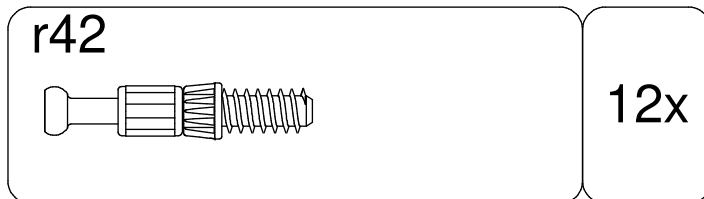

1:1

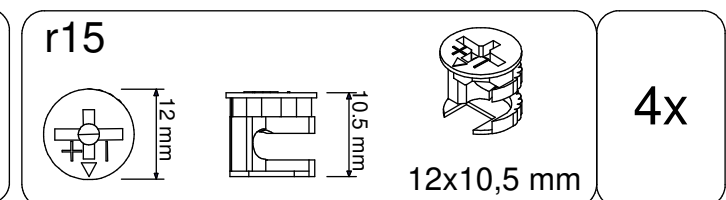
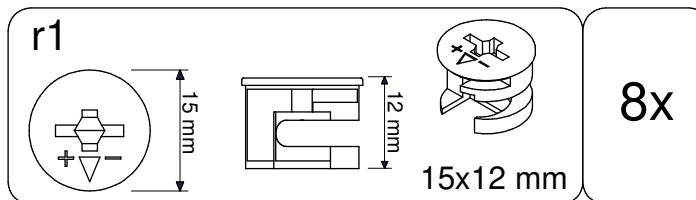
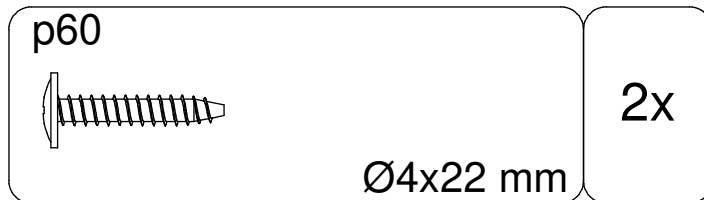
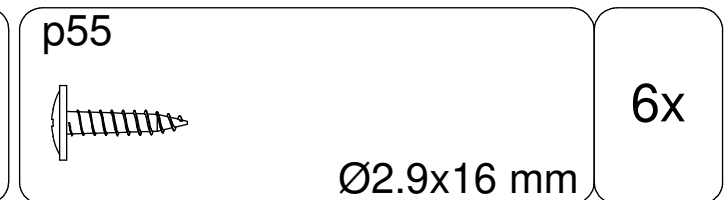
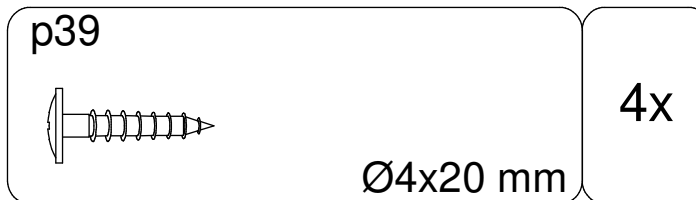
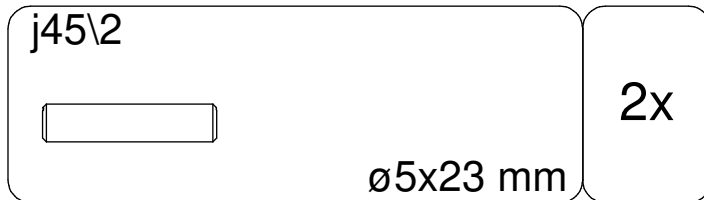
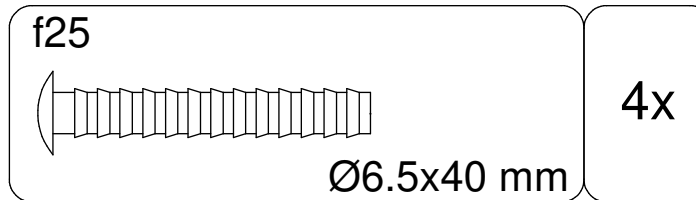
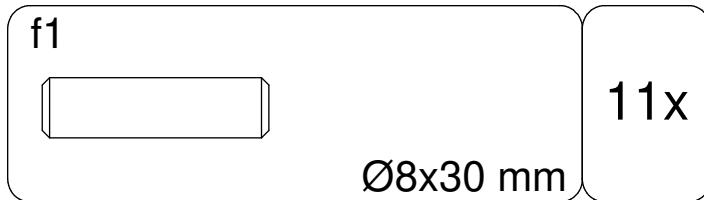
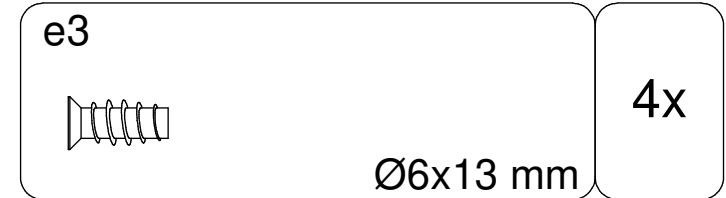
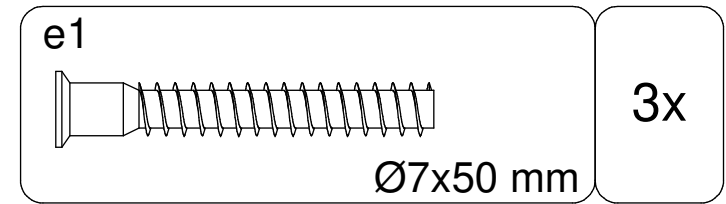
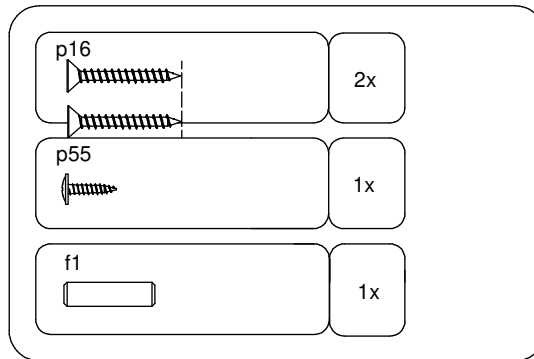
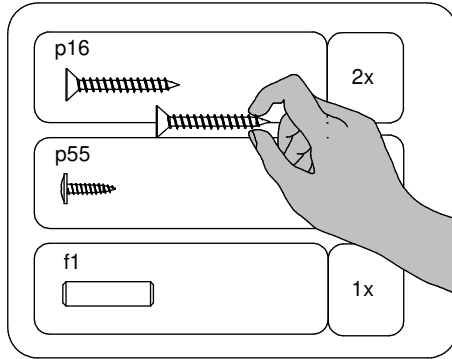

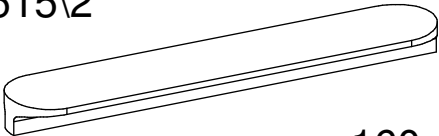
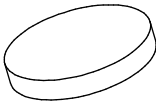
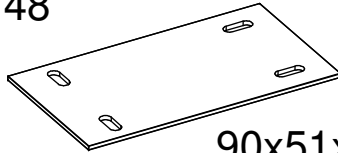
~~1:1~~

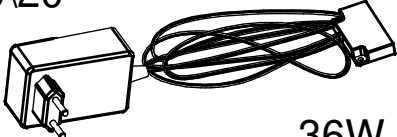
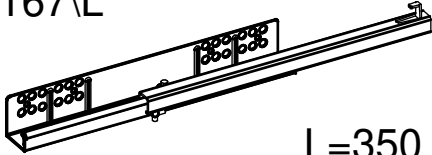
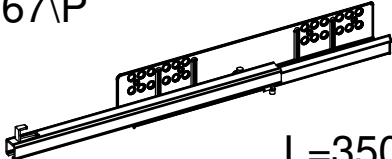
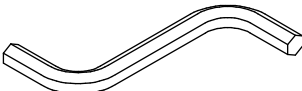
c515\2  160 mm	1x	k103  ø20x3,5 mm	2x	n148  90x51x1,5 mm	1x
o127\2 	1x	o70\20  36W 3P	1x	w167\L  L=350 mm	1x
w167\P  L=350 mm	1x	z1  4 mm	1x		

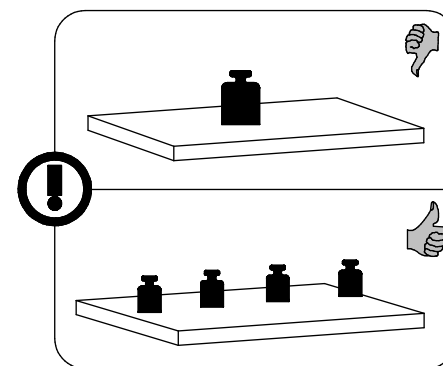
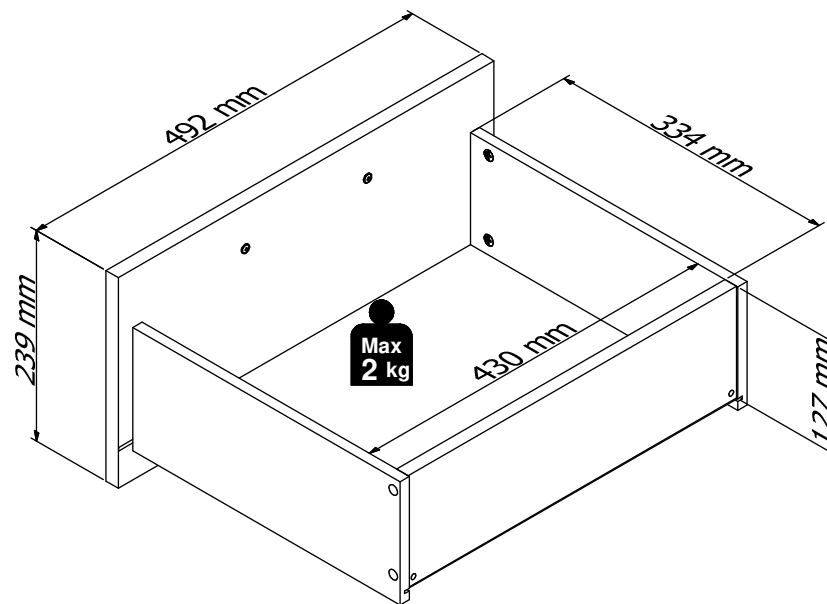
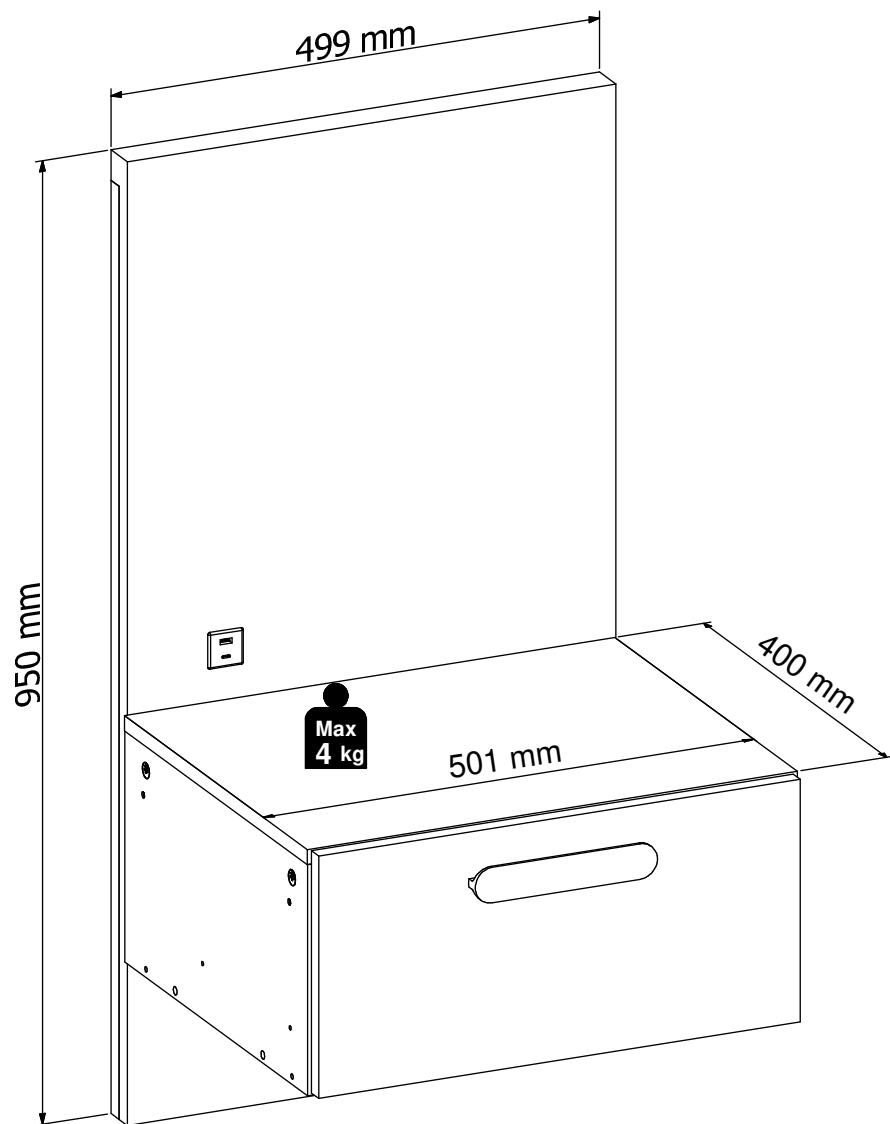

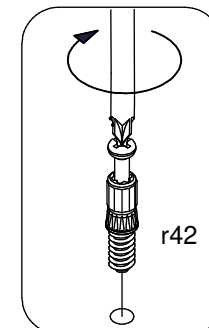
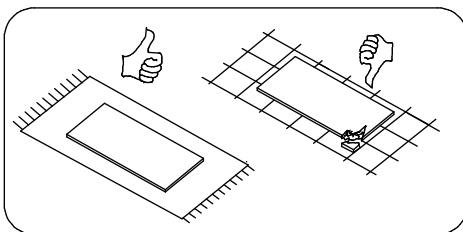
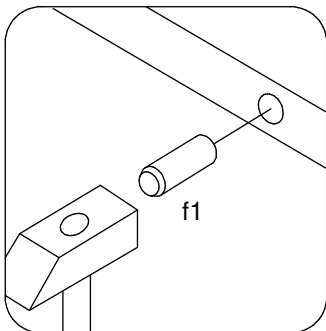
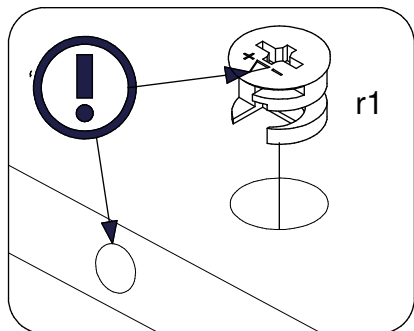
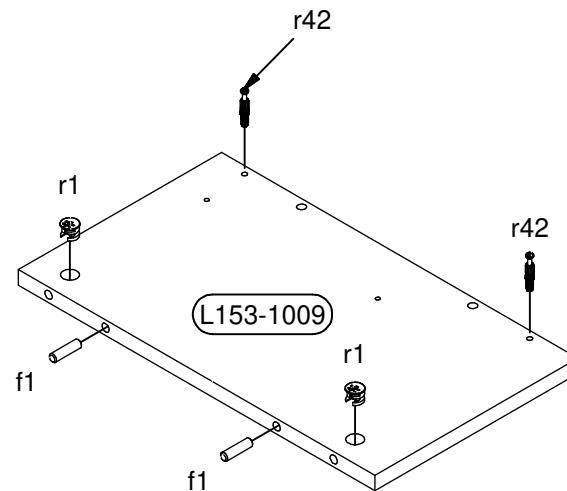
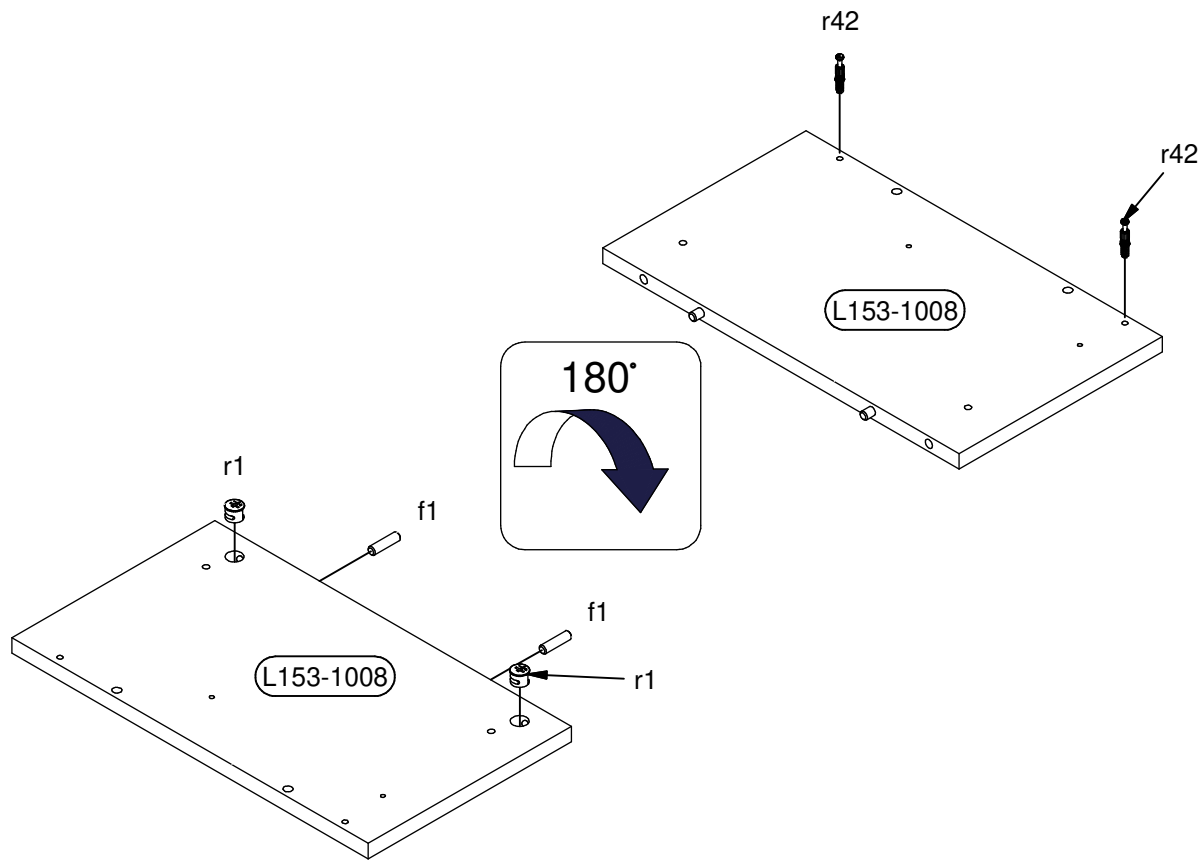
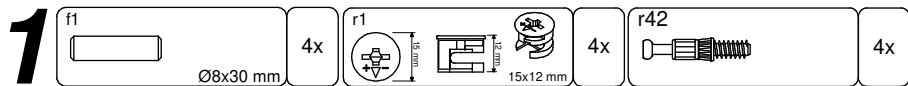

2

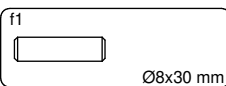

7x

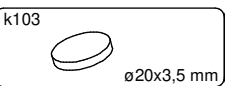

2x

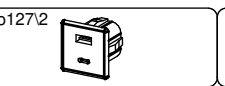

1x

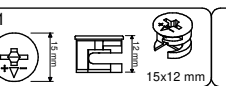

4x

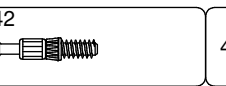

4x

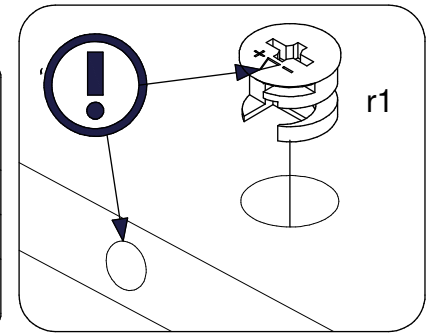
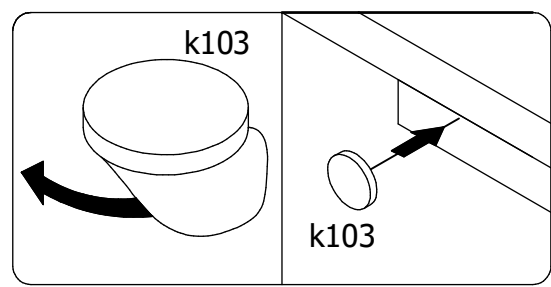
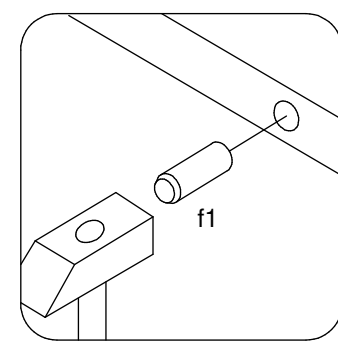
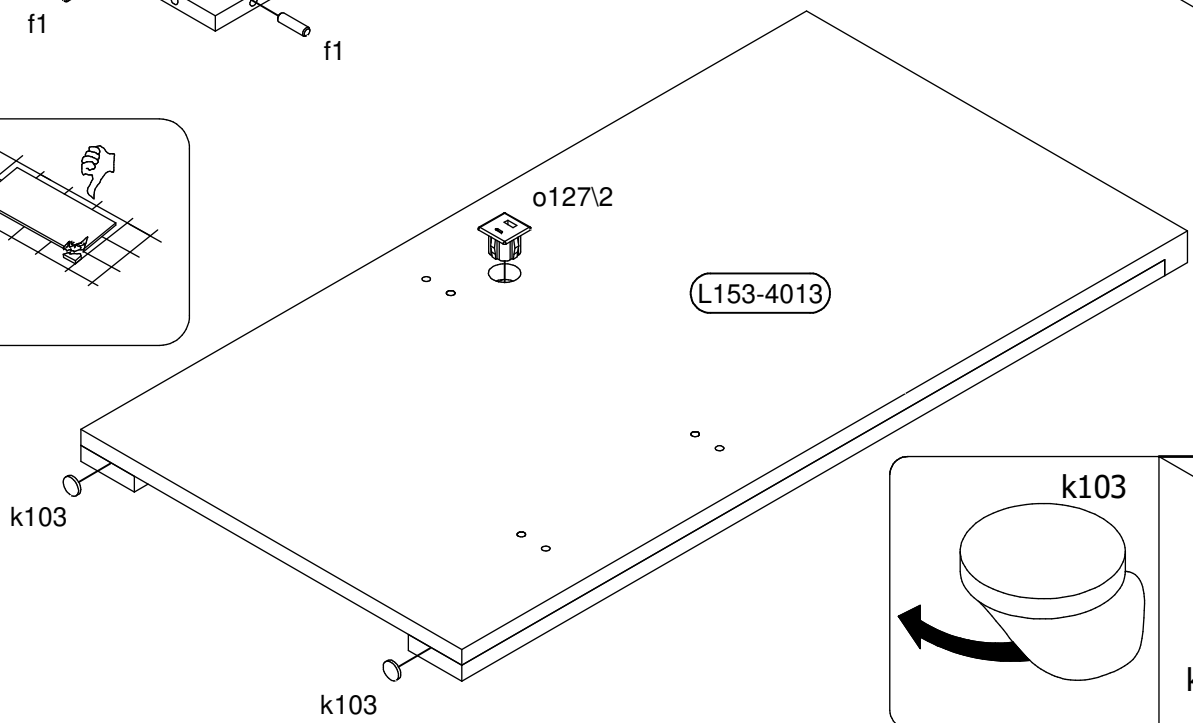
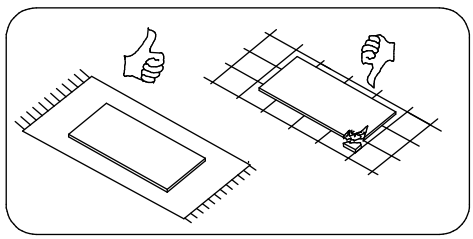
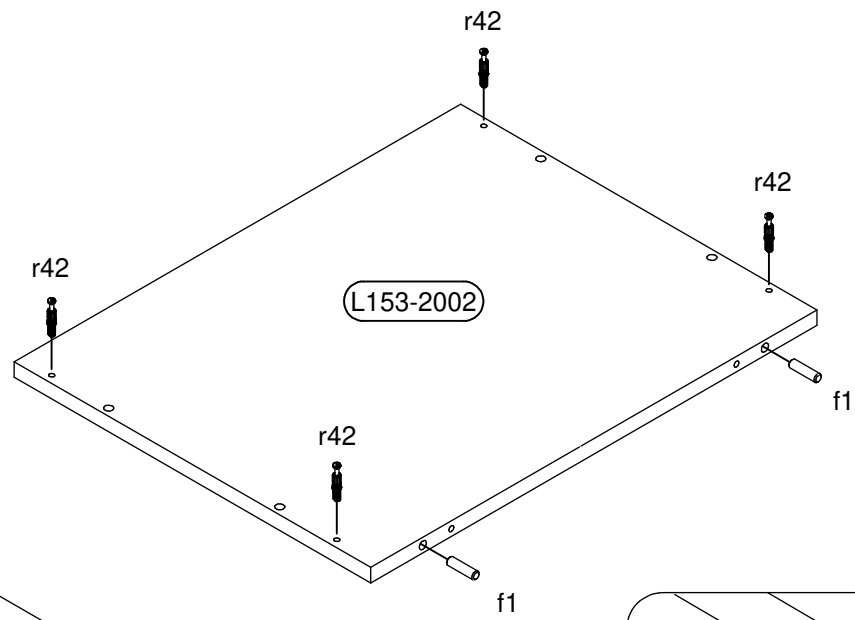
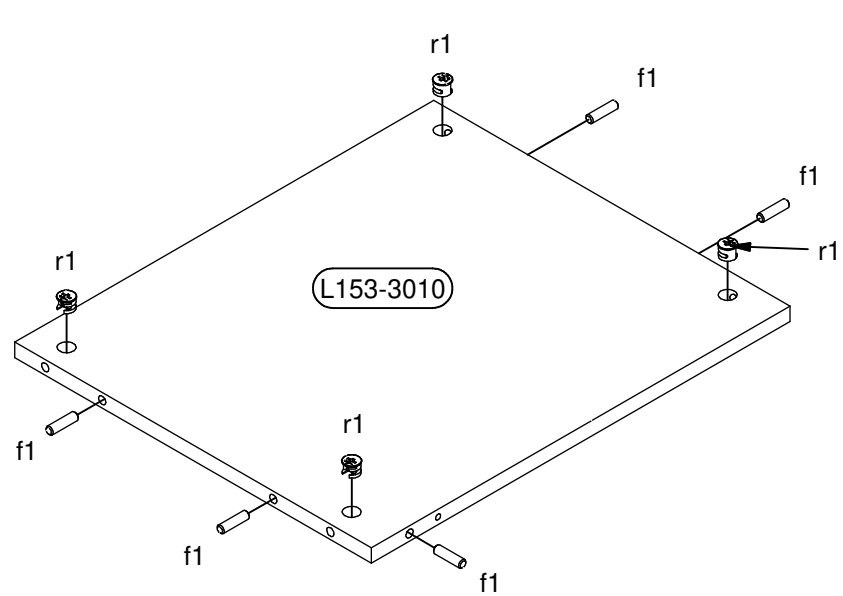

3

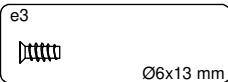

4x

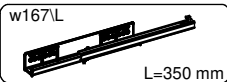

1x

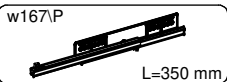

1x

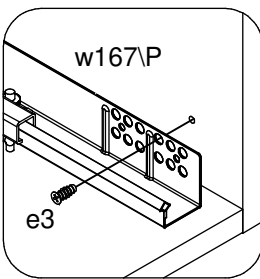
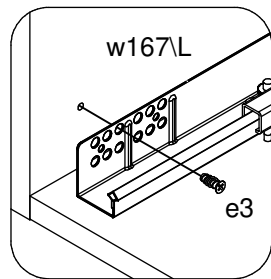
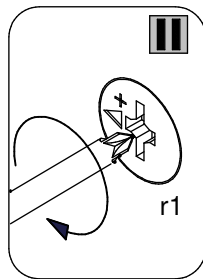
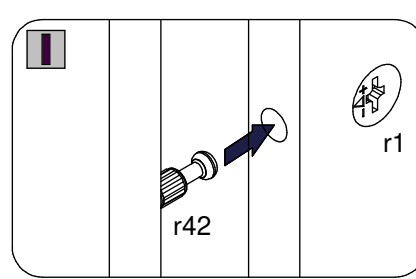
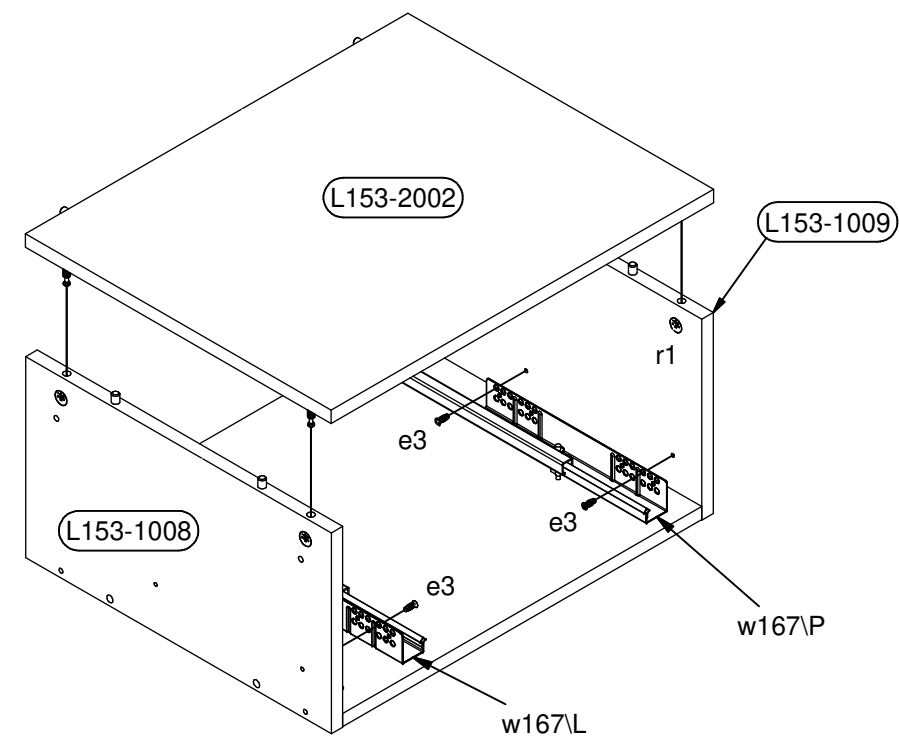
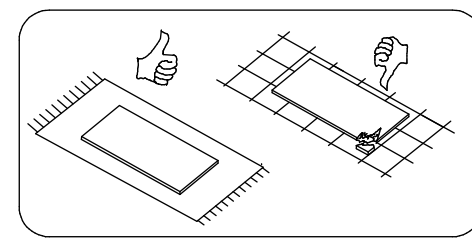
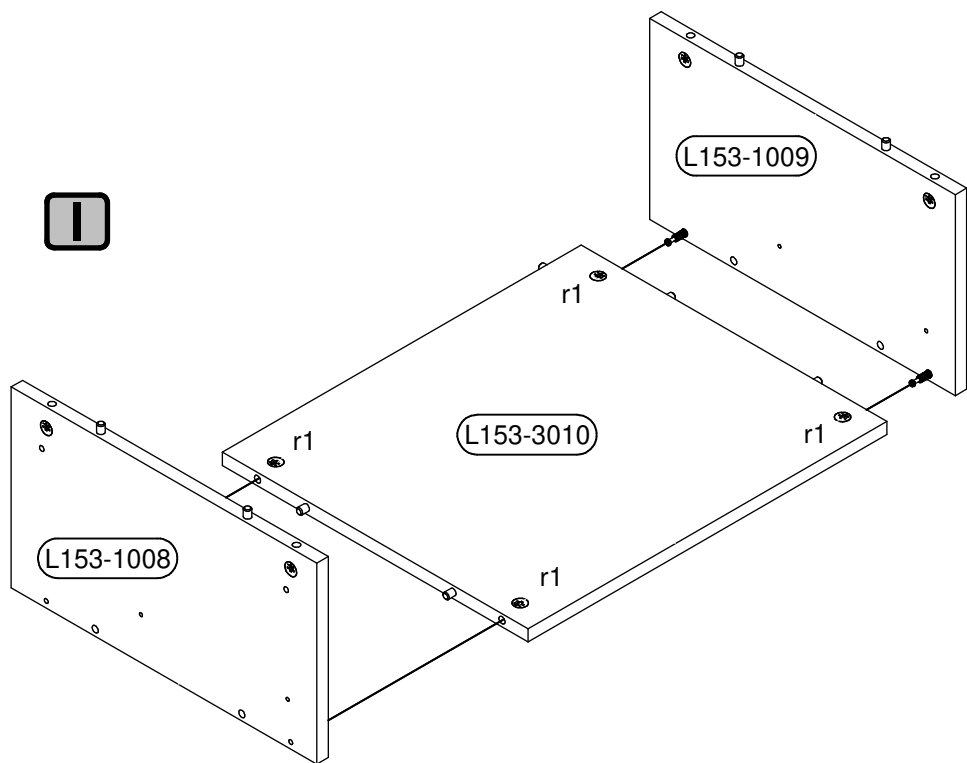



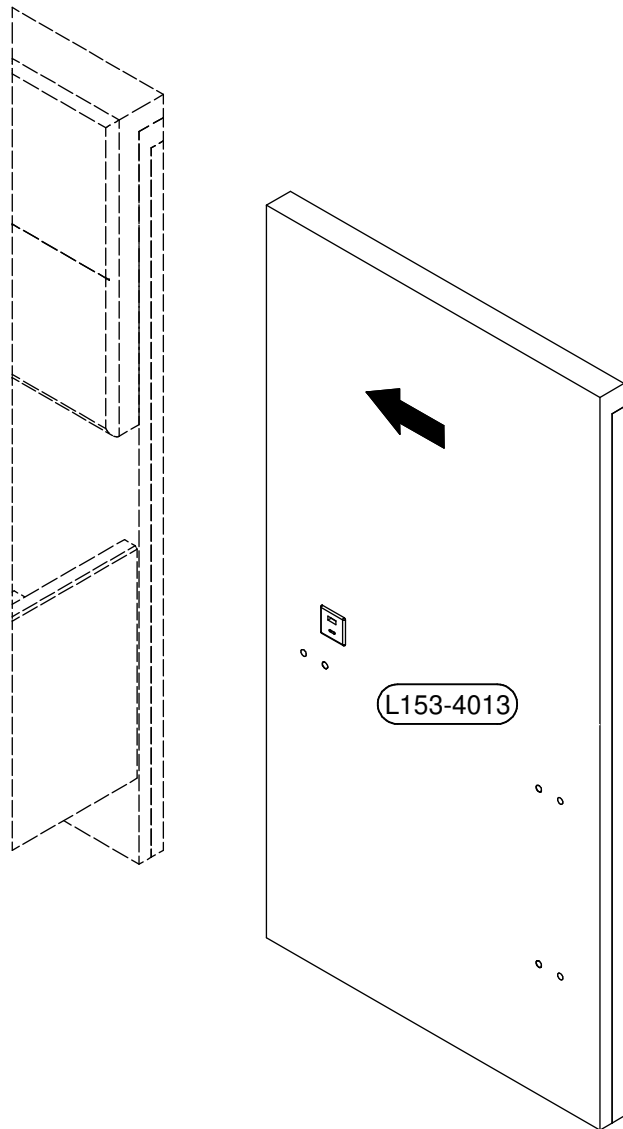



4

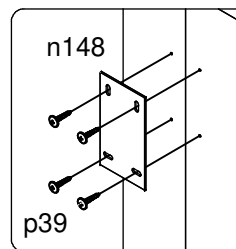
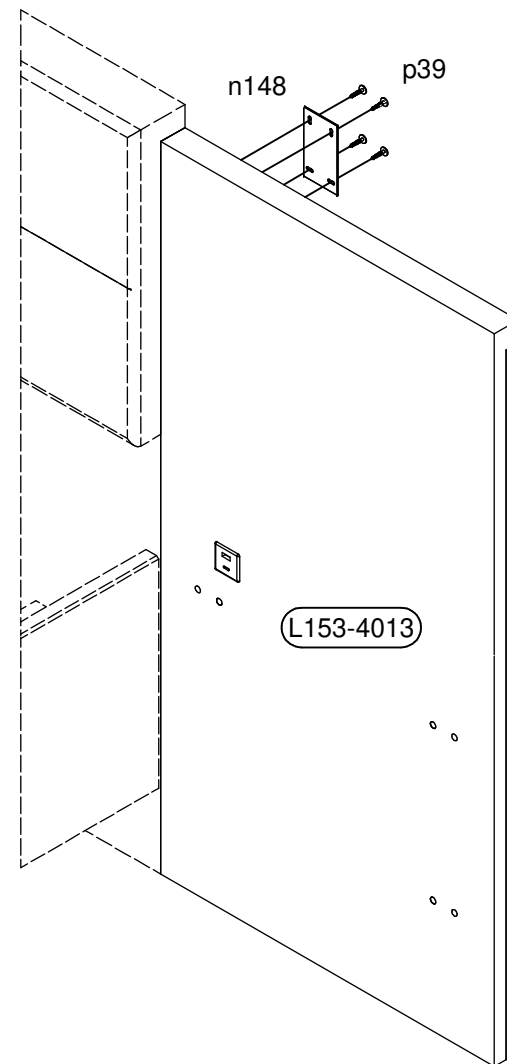

5

n148 90x51x1,5 mm 1x	o70\20 36W 3P 1x	p39 Ø4x20 mm 4x
----------------------------	------------------------	-----------------------



- 6 e1  3x Ø7x50 mm
- j29  M4x14 mm
- 4x j45\2  ø5x23 mm
- 2x z1  ∅ 4 mm
- 1x 

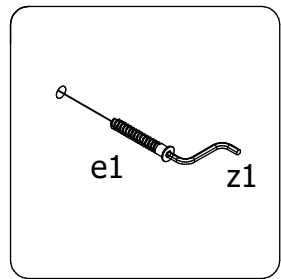
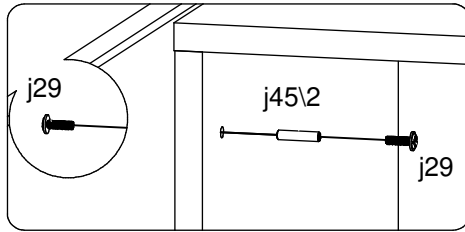
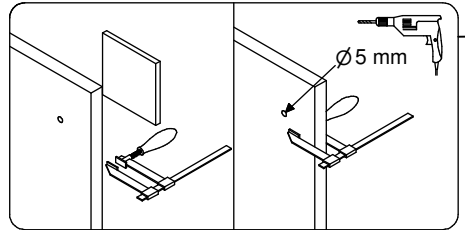
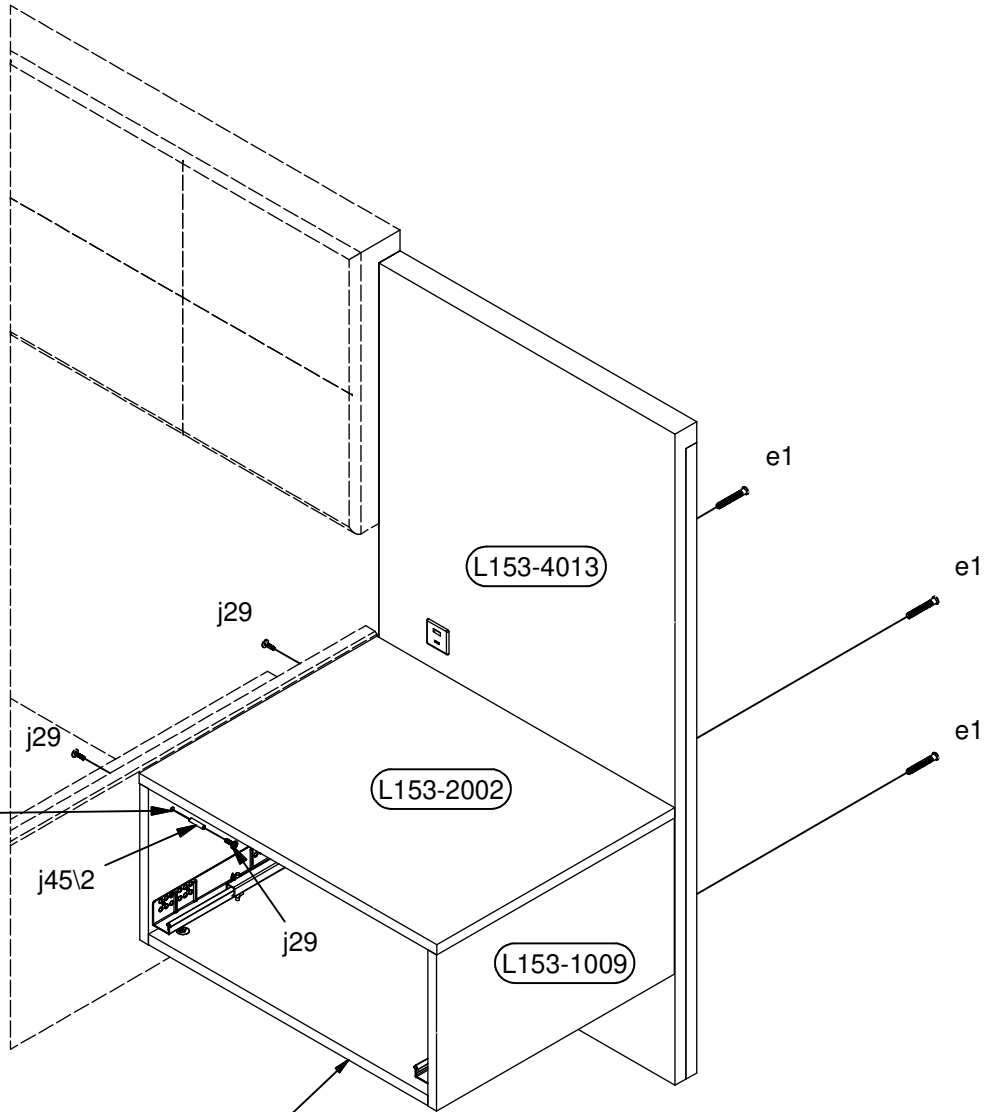

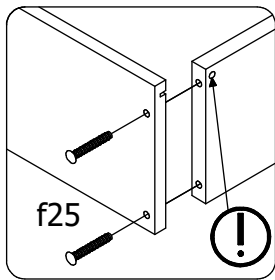
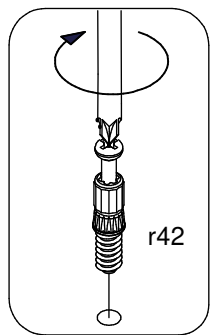
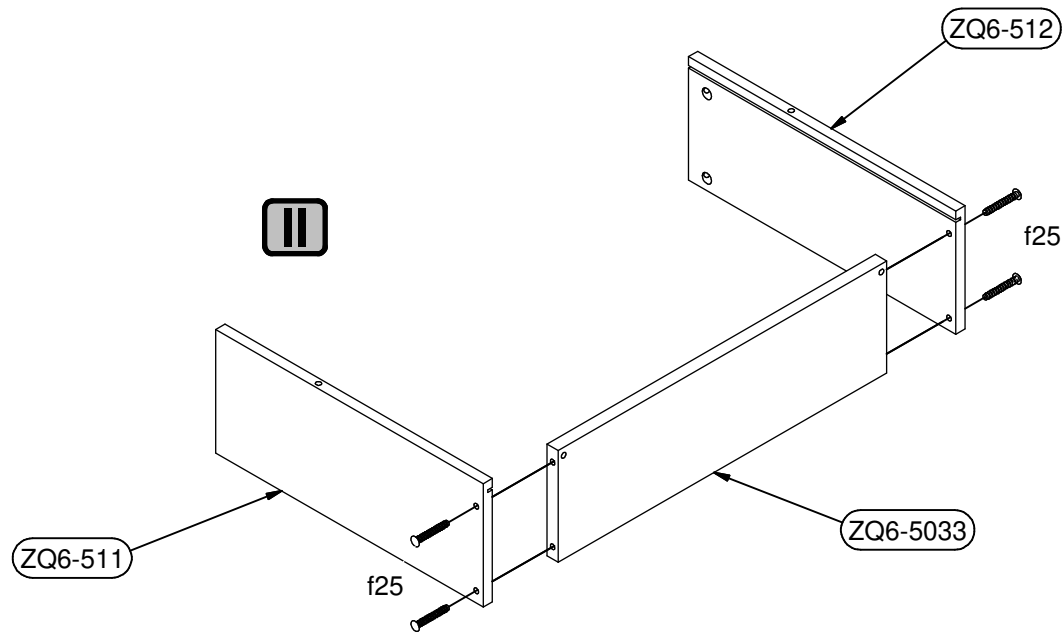
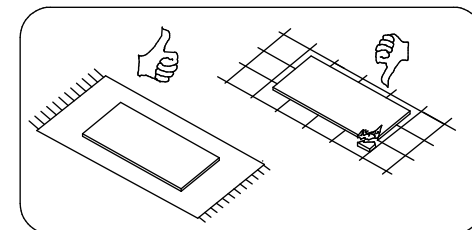
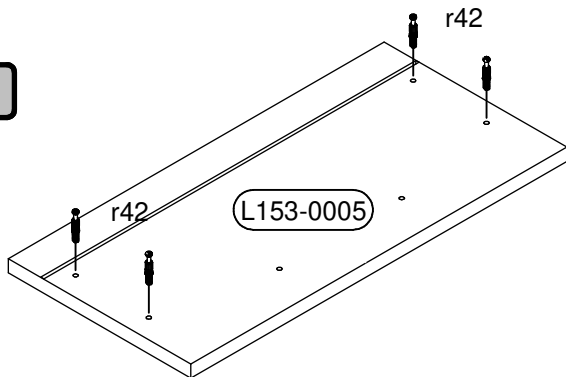
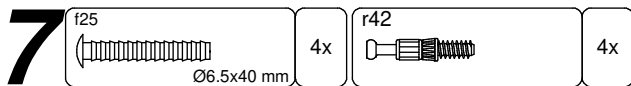

- 8 c515/2 160 mm 1x
- p60 Ø4x22 mm 2x
- p55 Ø2.9x16 mm 4x
- r15 4x
- 12x10,5 mm 4x

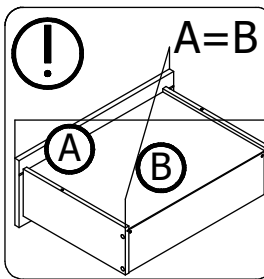
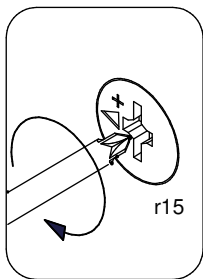
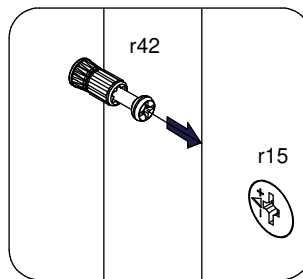
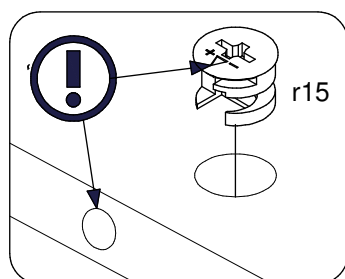
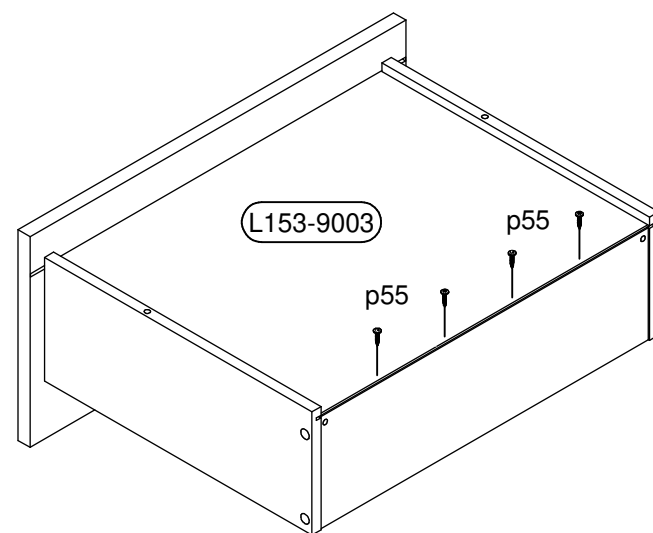
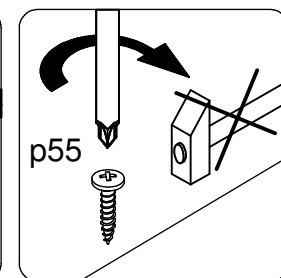
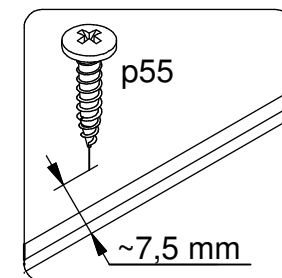
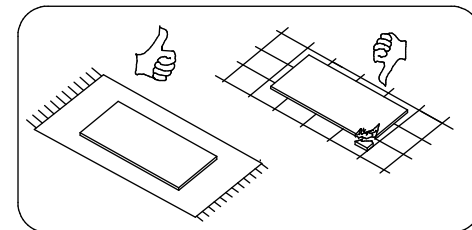
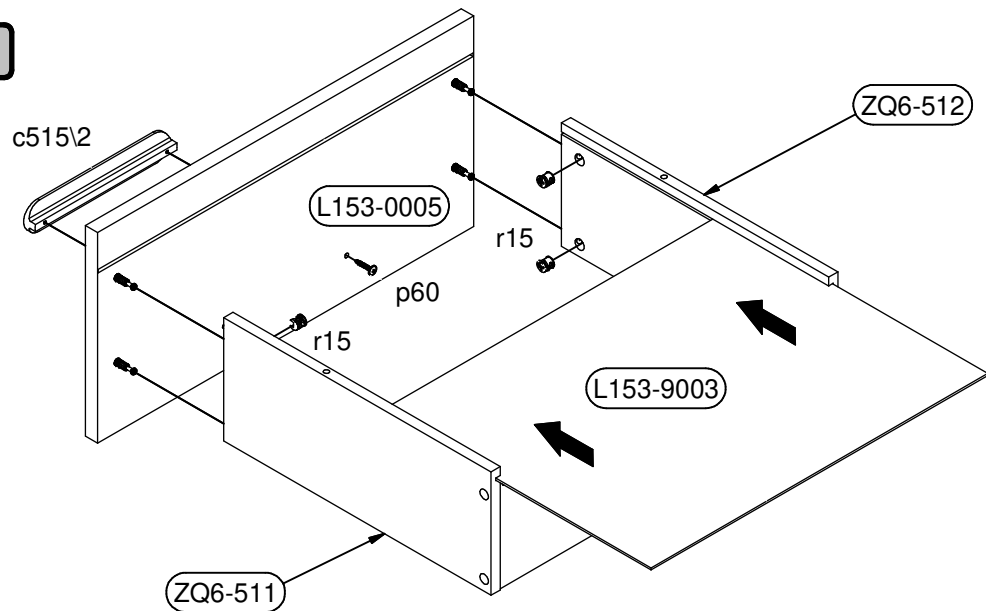

**9**

p55

Ø2.9x16 mm

2x

