

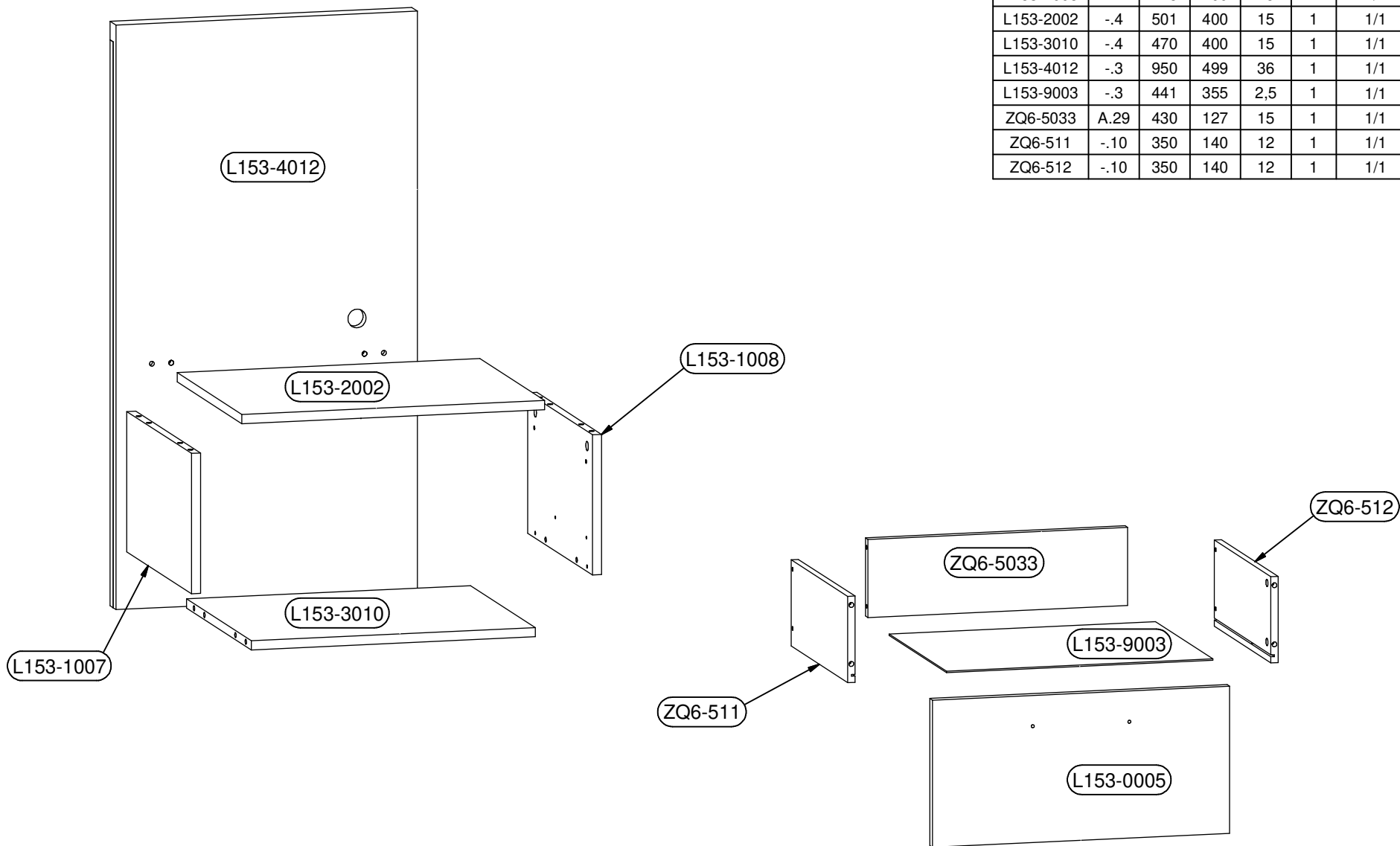

B1	B2	C1	C2	C3	C4	D
L153-0005	-.5	492	239	16	1	1/1
L153-1007	-.4	228	400	15	1	1/1
L153-1008	-.4	228	400	15	1	1/1
L153-2002	-.4	501	400	15	1	1/1
L153-3010	-.4	470	400	15	1	1/1
L153-4012	-.3	950	499	36	1	1/1
L153-9003	-.3	441	355	2,5	1	1/1
ZQ6-5033	A.29	430	127	15	1	1/1
ZQ6-511	-.10	350	140	12	1	1/1
ZQ6-512	-.10	350	140	12	1	1/1

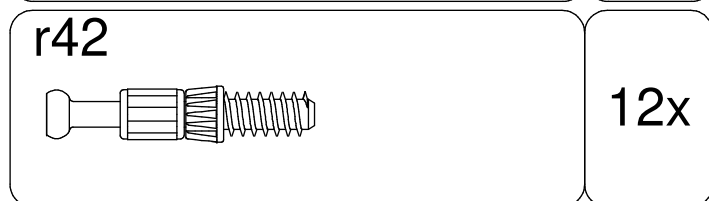

1:1

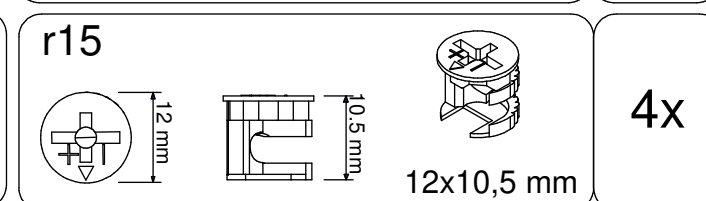
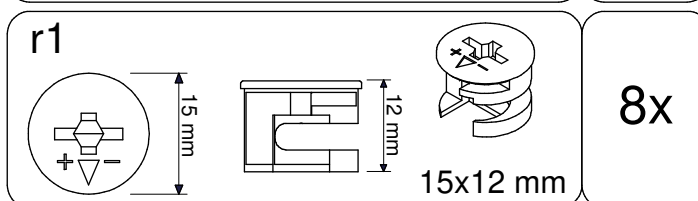
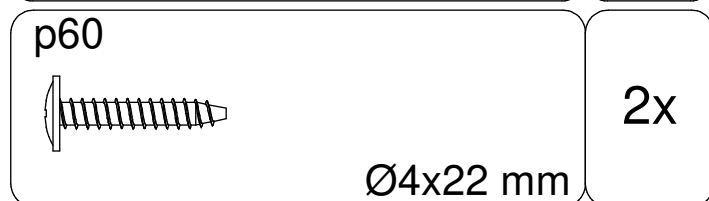
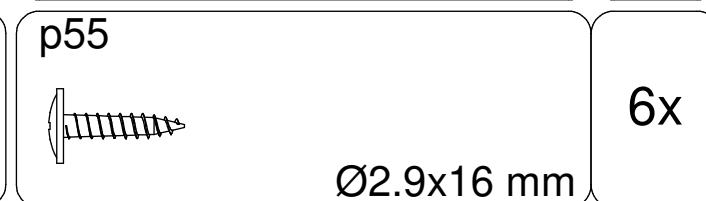
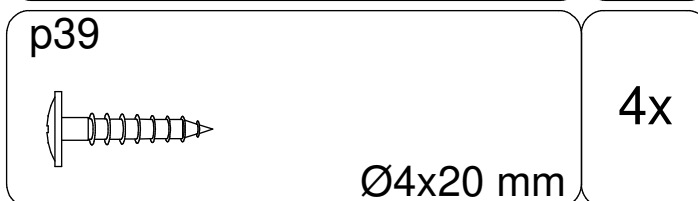
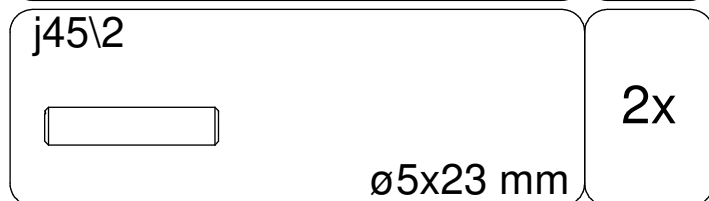
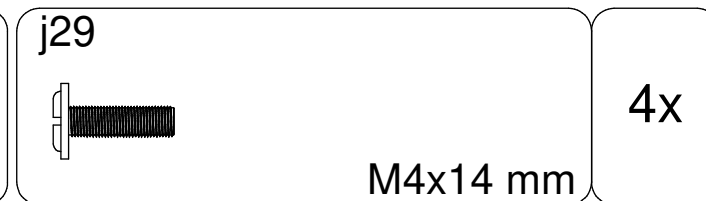
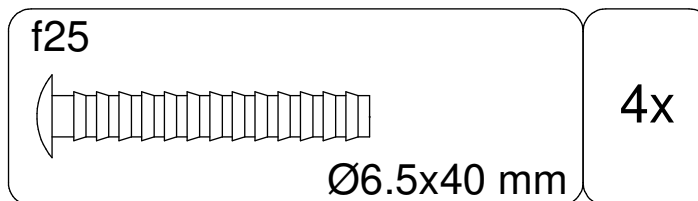
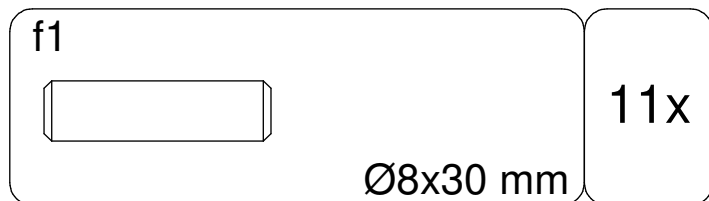
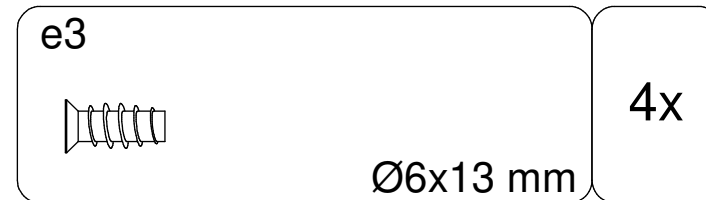
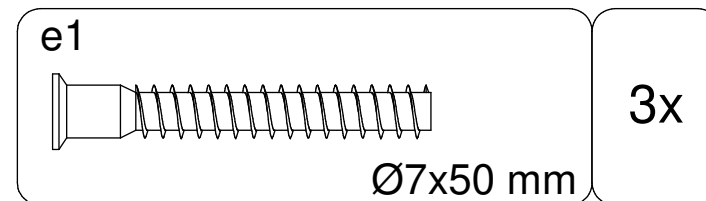
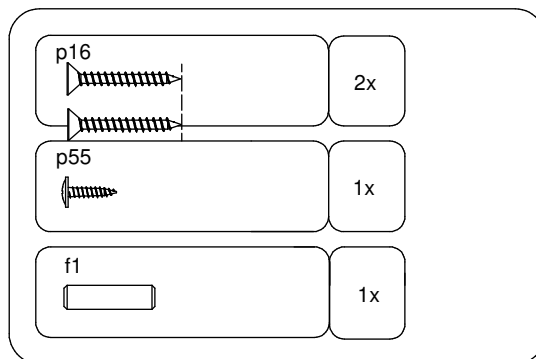
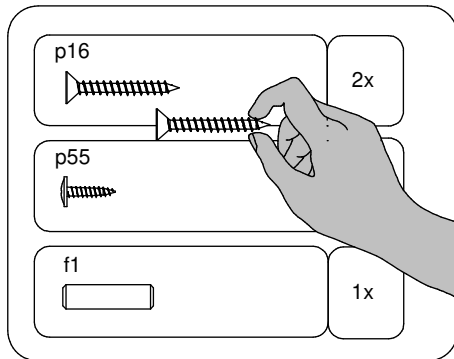

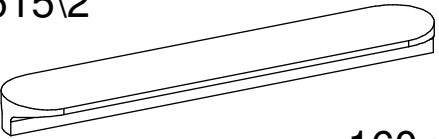

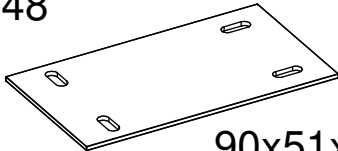
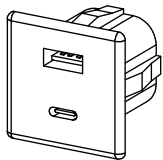
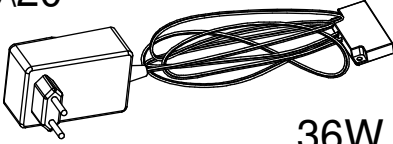
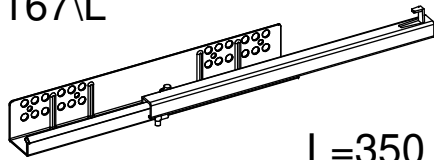
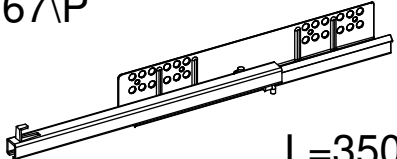
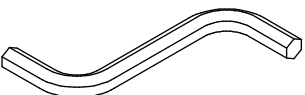
~~1:1~~

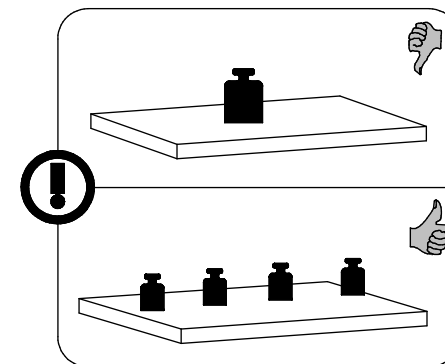
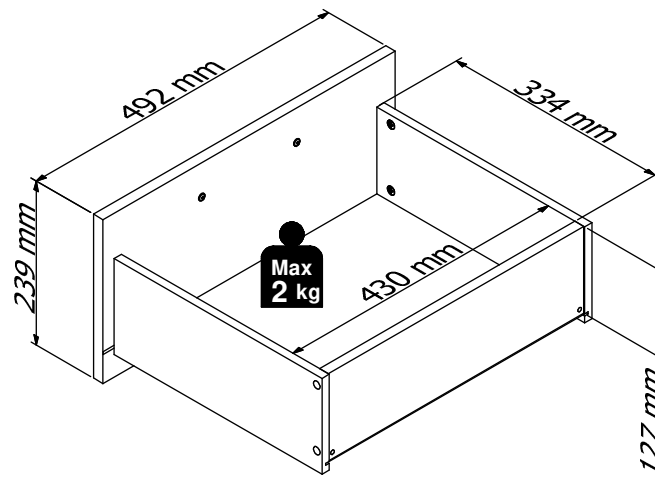
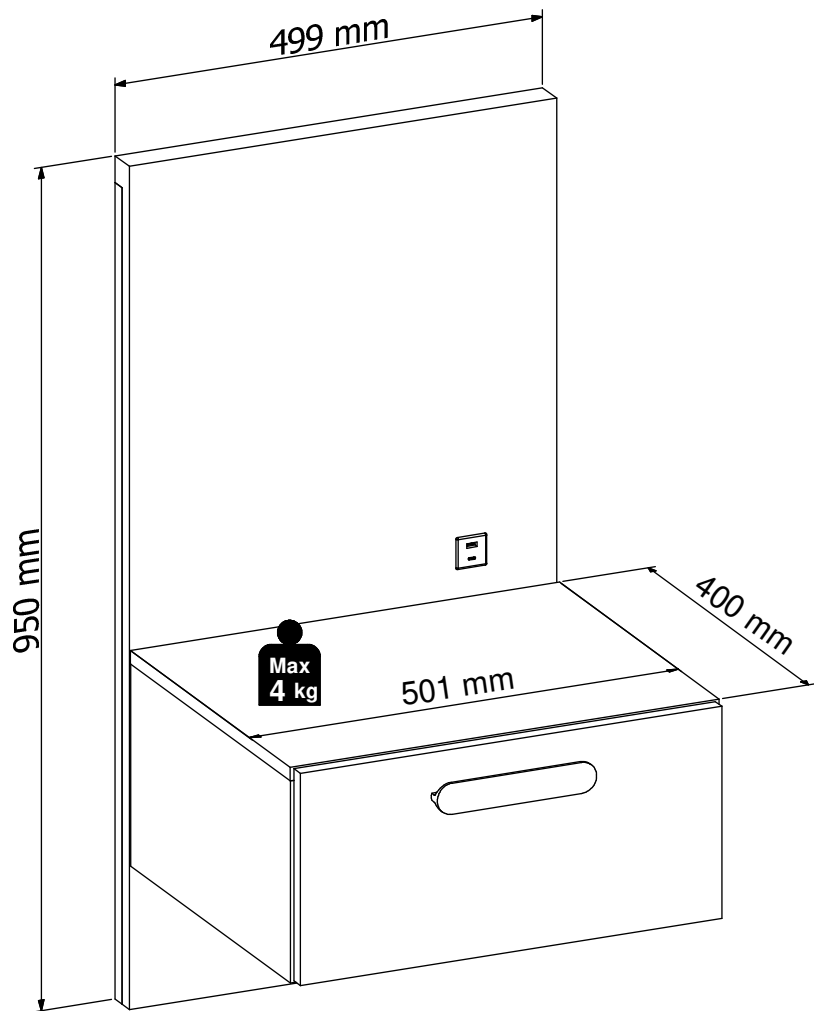
c515\2  160 mm	1x	k103  ø20x3,5 mm	2x	n148  90x51x1,5 mm	1x
o127\2 	1x	o70\20  36W 3P	1x	w167\L  L=350 mm	1x
w167\P  L=350 mm	1x	z1  4 mm	1x		

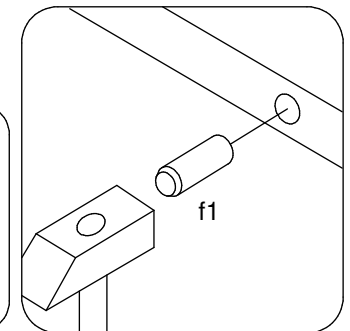
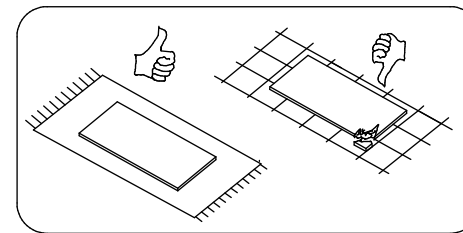
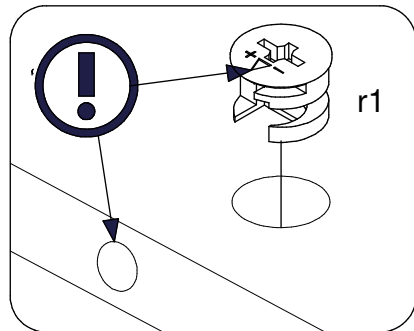
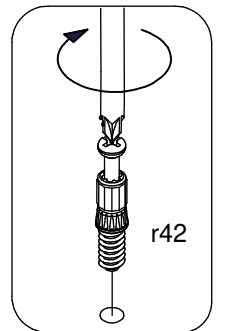
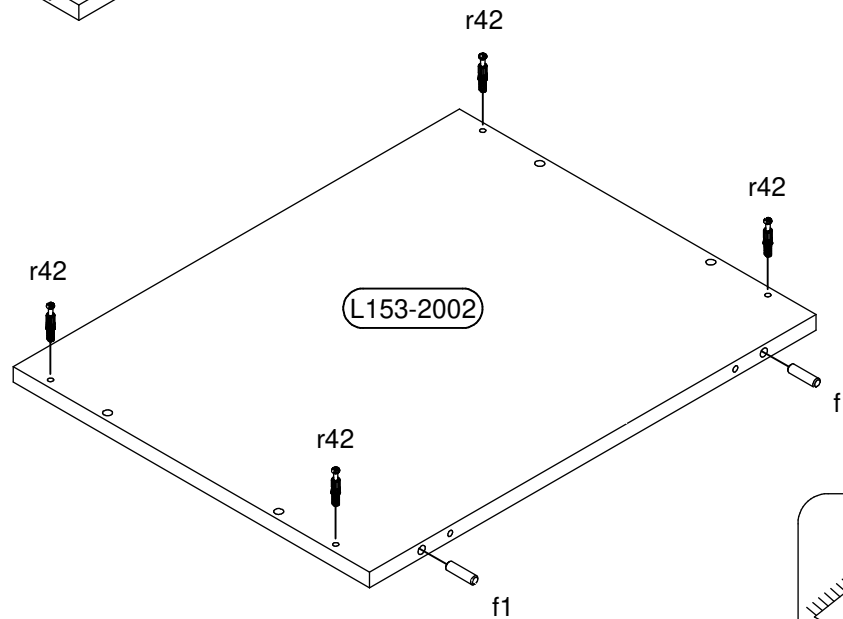
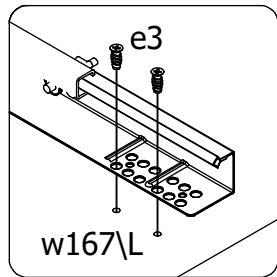
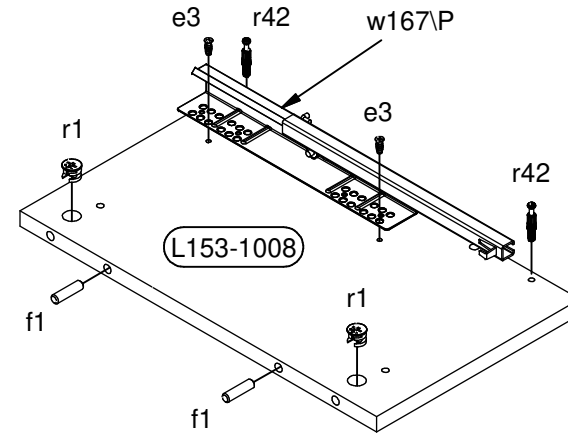
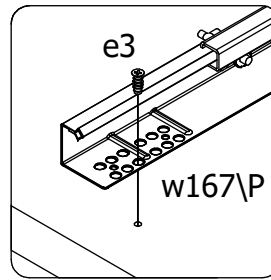
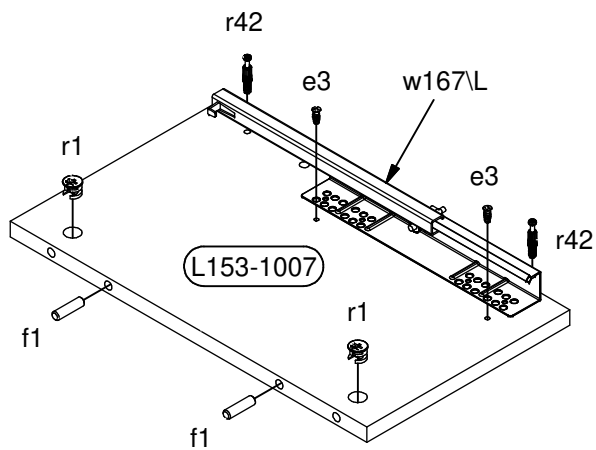

- 1 e3 4x  $\varnothing 6 \times 13 \text{ mm}$
- f1 4x  $\varnothing 8 \times 30 \text{ mm}$
- r1 6x 15x12 mm
- r42 4x
- w167L 8x L=350 mm
- w167P 1x L=350 mm

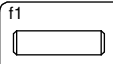

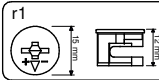
2 f1  Ø8x30 mm 5x k103  ø20x3,5 mm 2x o127/2  1x r1  15x12 mm 4x

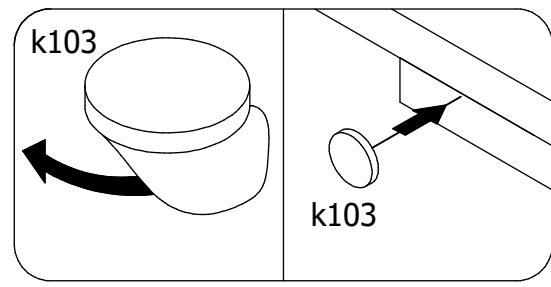
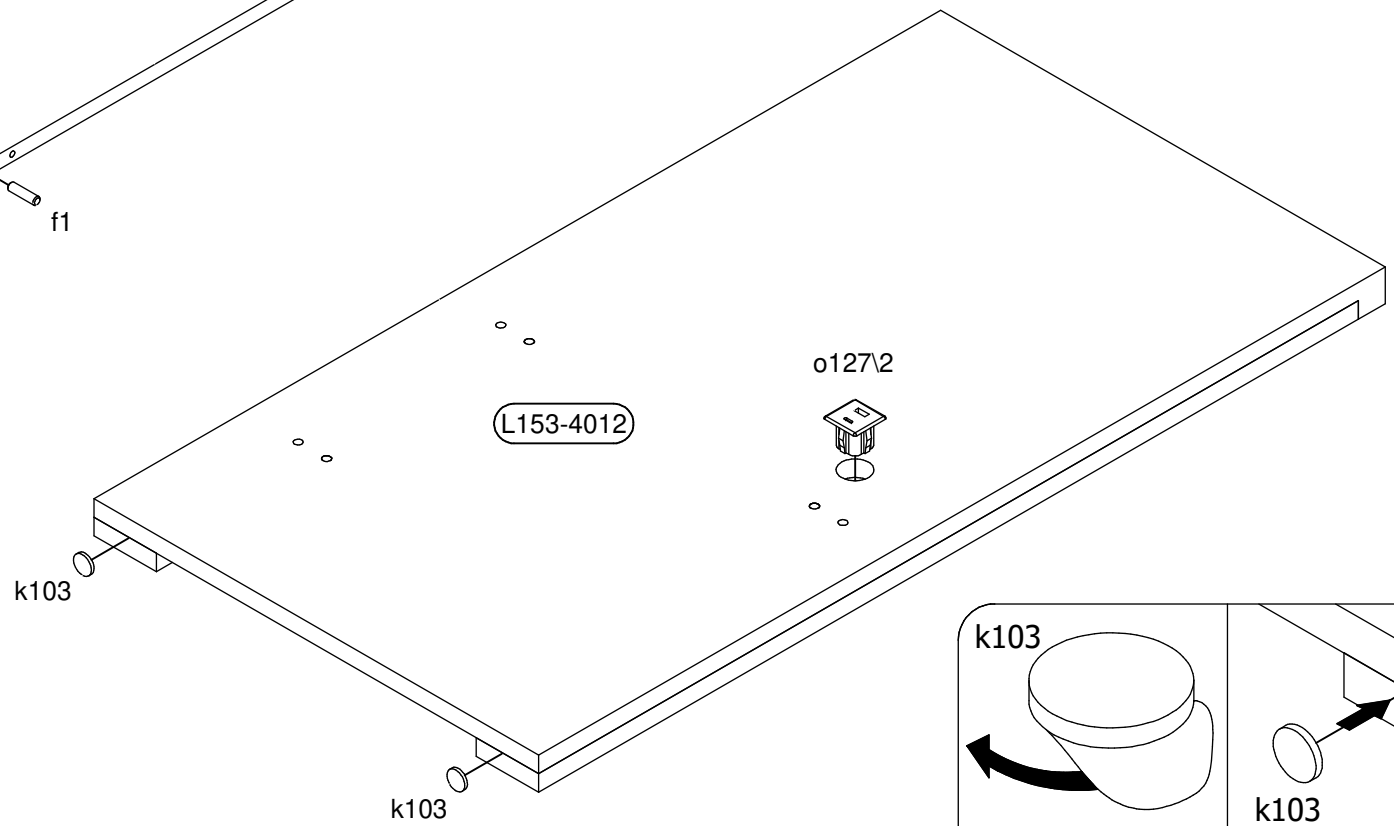
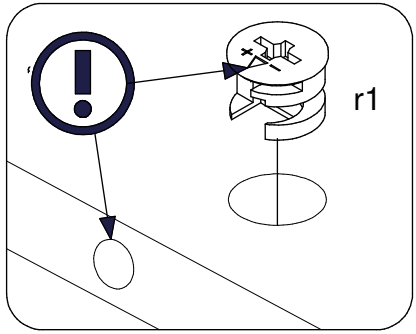
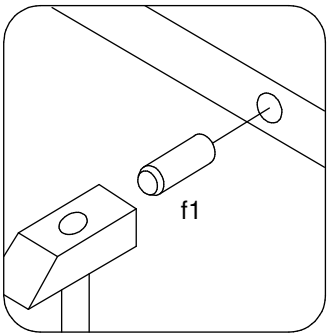
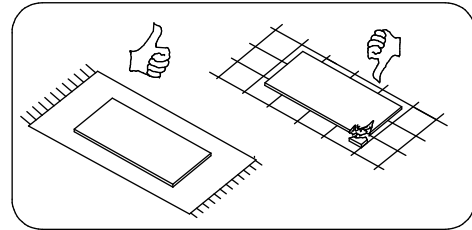
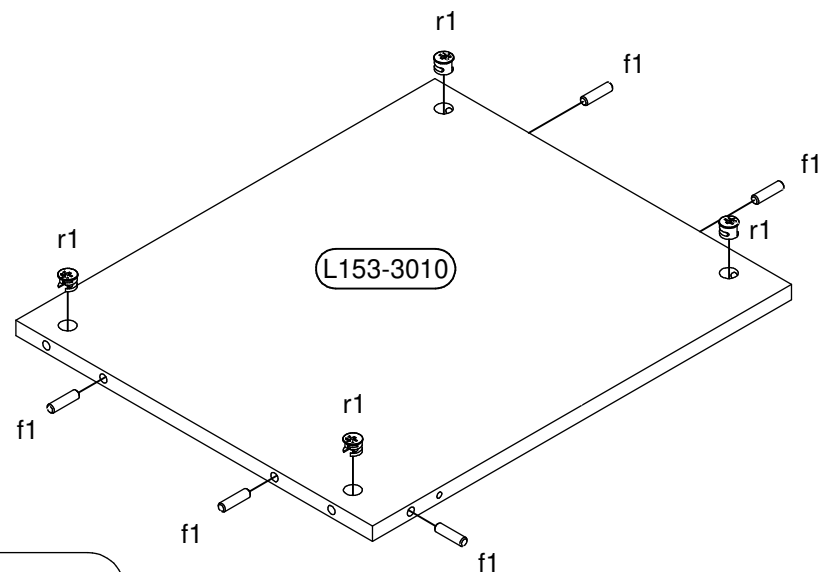

3

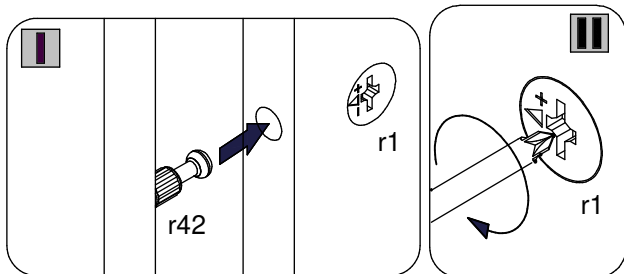
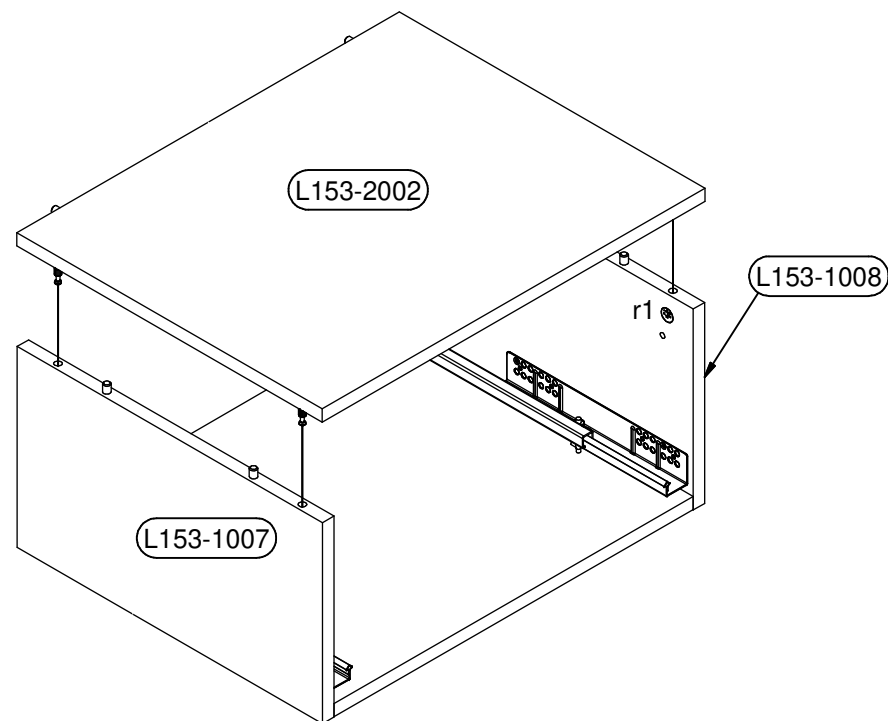
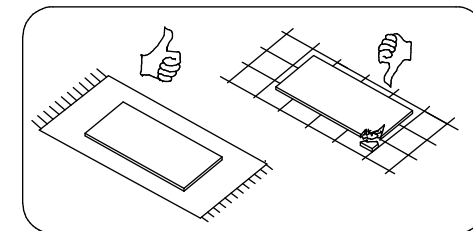
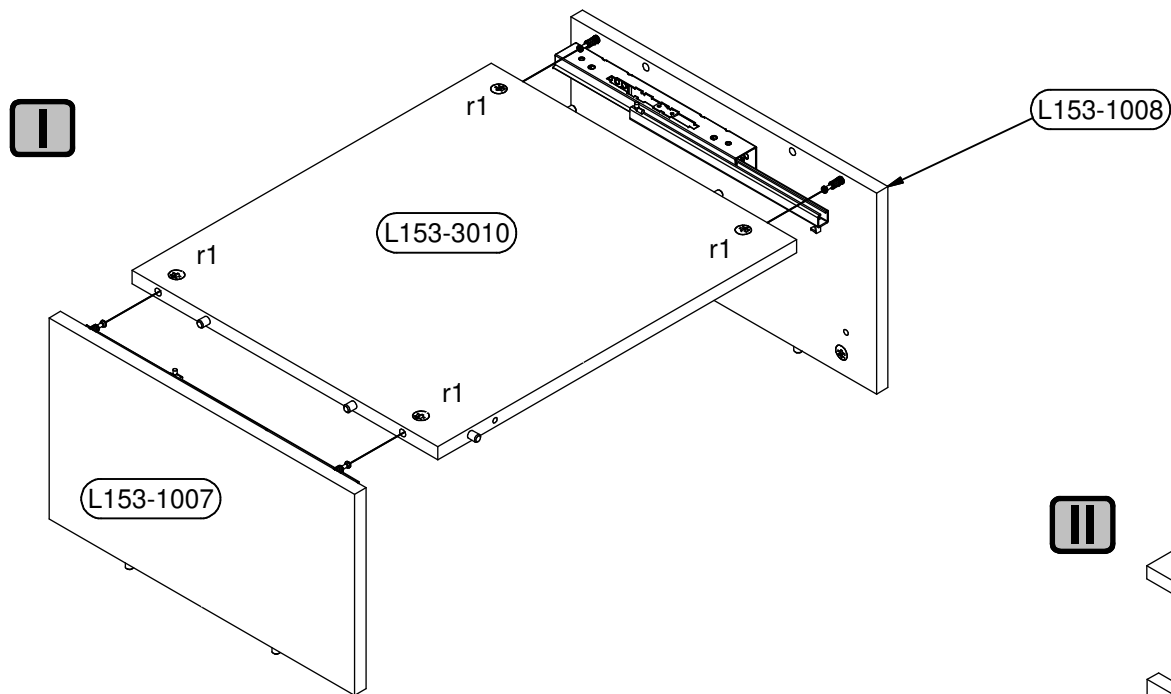

4

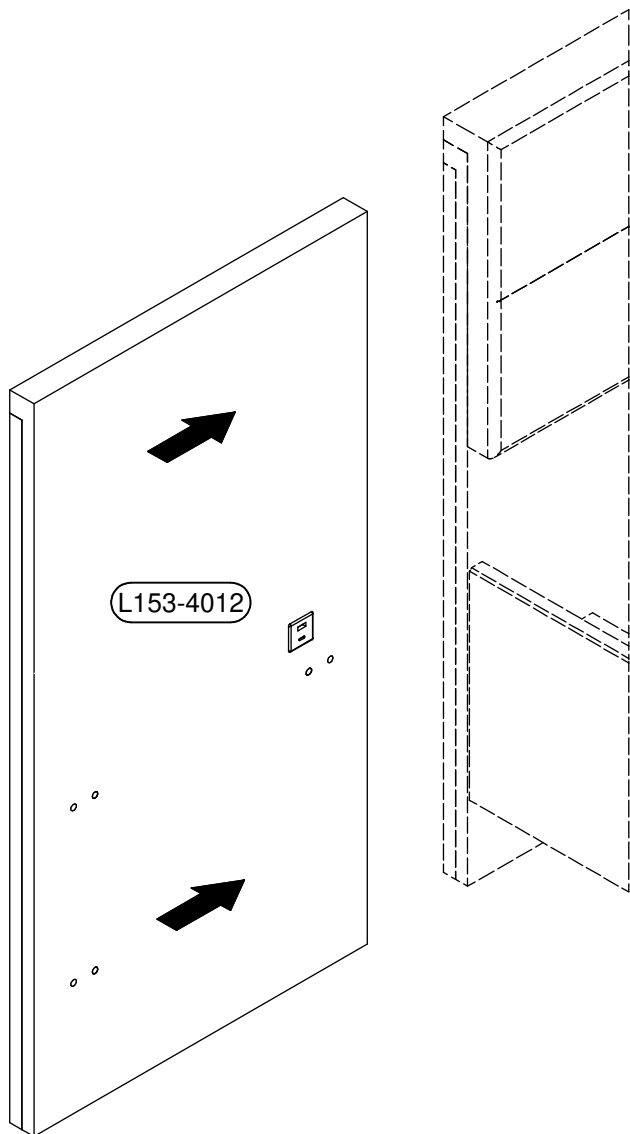

5

- |                            |                        |
|----------------------------|------------------------|
| n148<br>90x51x1,5 mm<br>1x | o70/20<br>36W 3P<br>1x |
| p39<br>Ø4x20 mm<br>4x      |                        |

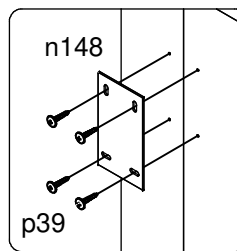
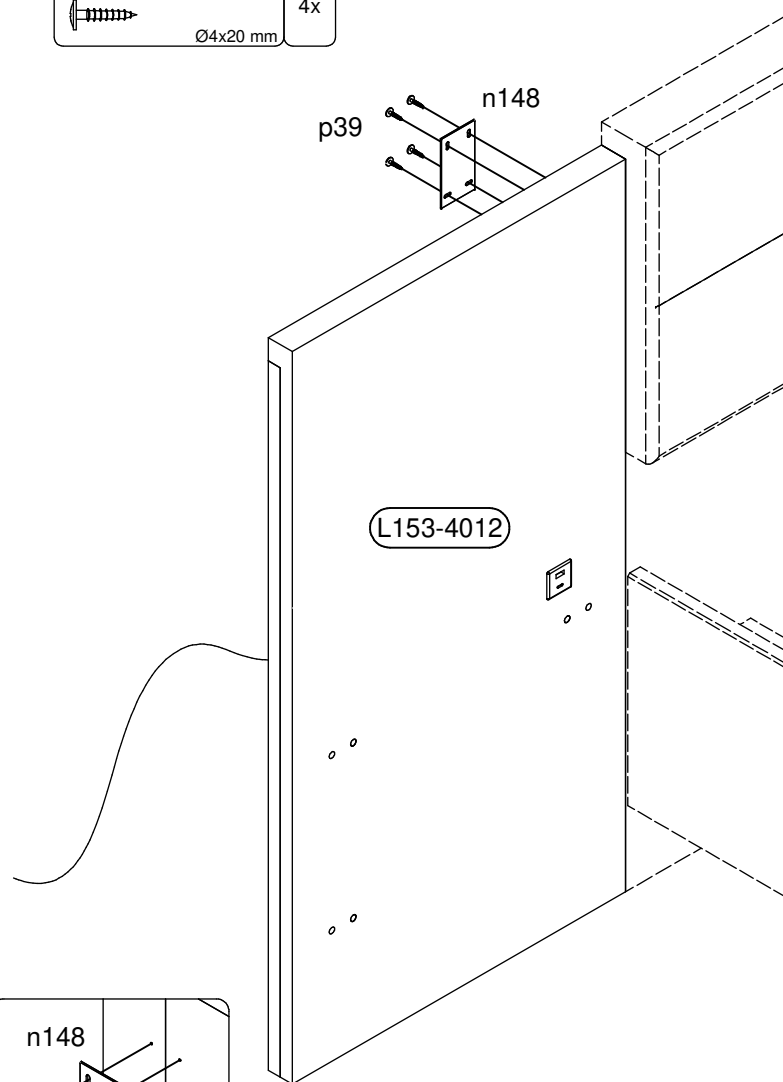

6

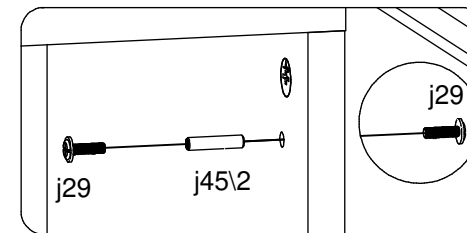
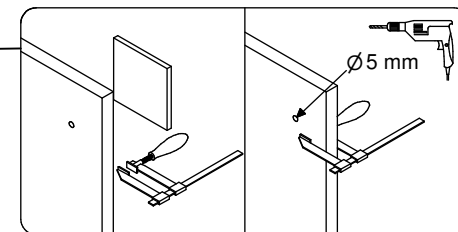
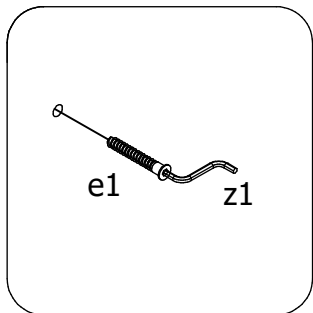
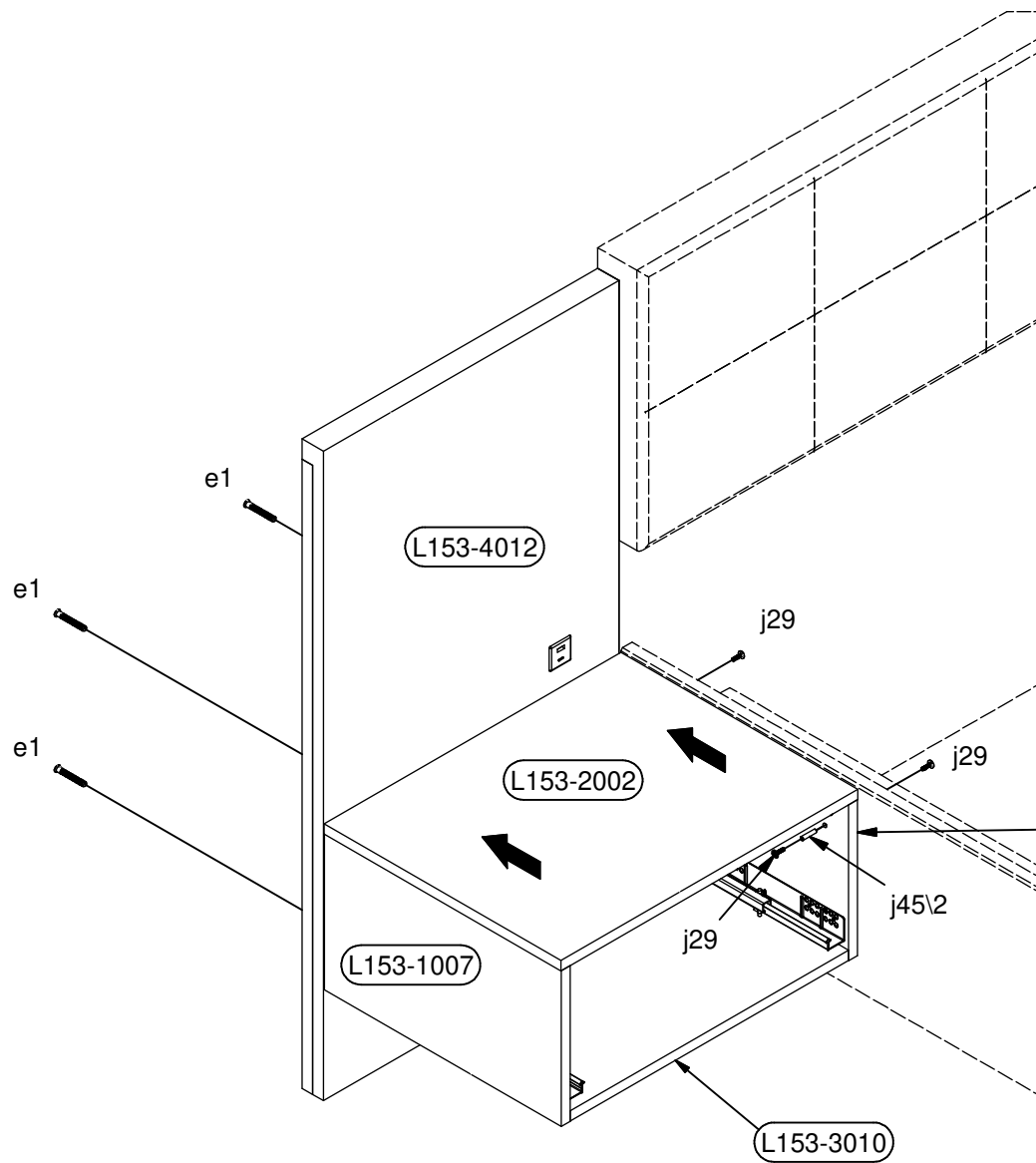
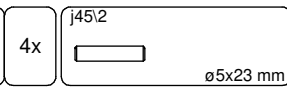
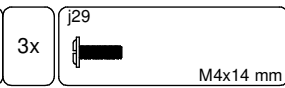
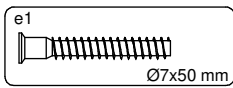

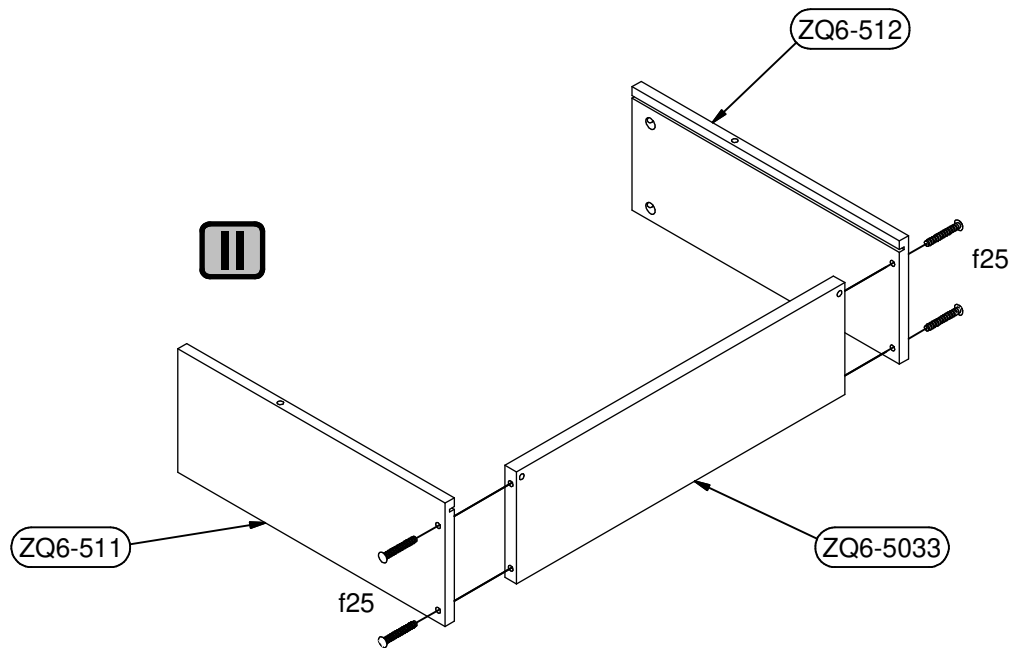
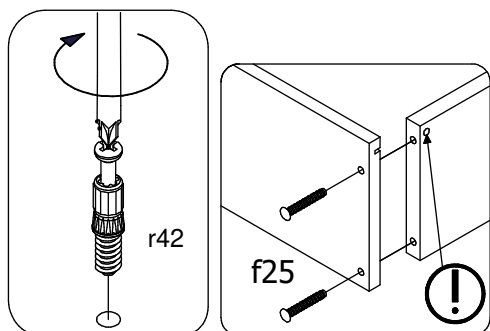
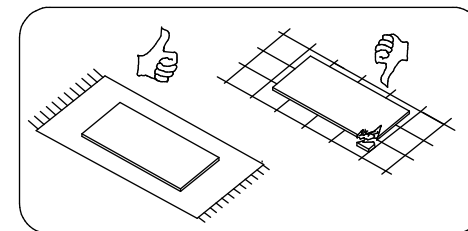
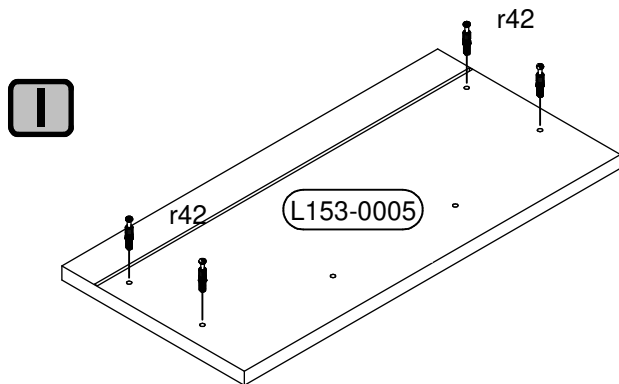
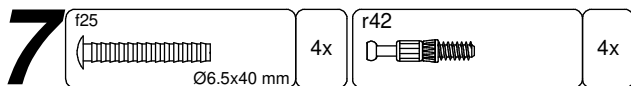

8	c515/2 160 mm	1x	p60 Ø4x22 mm	2x	p55 Ø2.9x16 mm	4x	r15 12x10,5 mm	4x

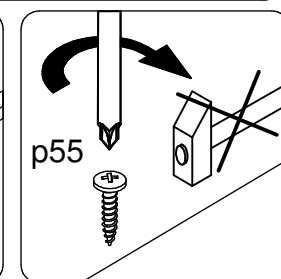
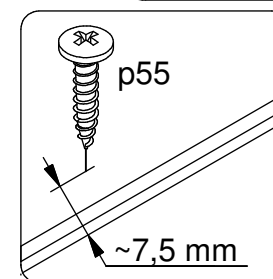
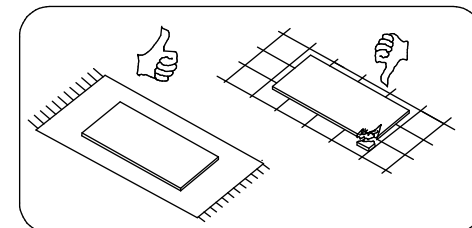
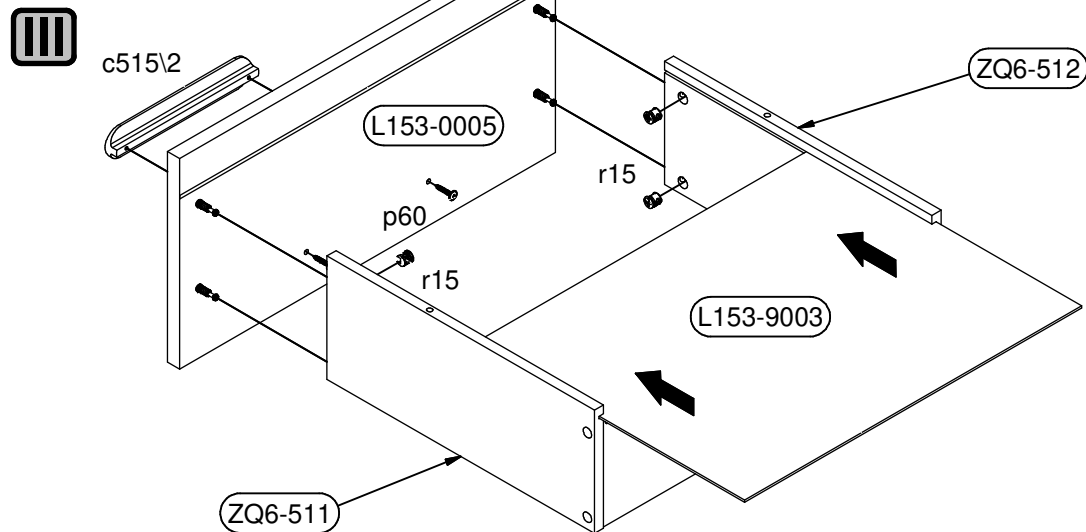

IV

