

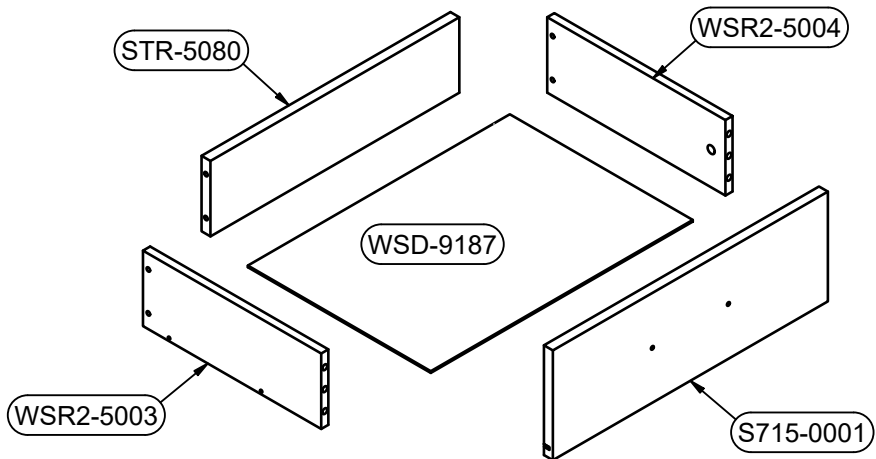

B1	B2	C1	C2	C3	C4	D
S715-0001	-	463	160	15	2	1/1
S715-1001	-	330	351	15	1	1/1
S715-1002	-	330	351	15	1	1/1
S715-2001	-	500	352	15	1	1/1
S715-2002	-	500	352	15	1	1/1
S715-9001	-	340	479	2,5	1	1/1
STR-5080	-	419	110	15	2	1/1
WSD-9187	-	441	308	2,5	2	1/1
WSR2-5003	-2	300	110	12	2	1/1
WSR2-5004	-3	300	110	12	2	1/1

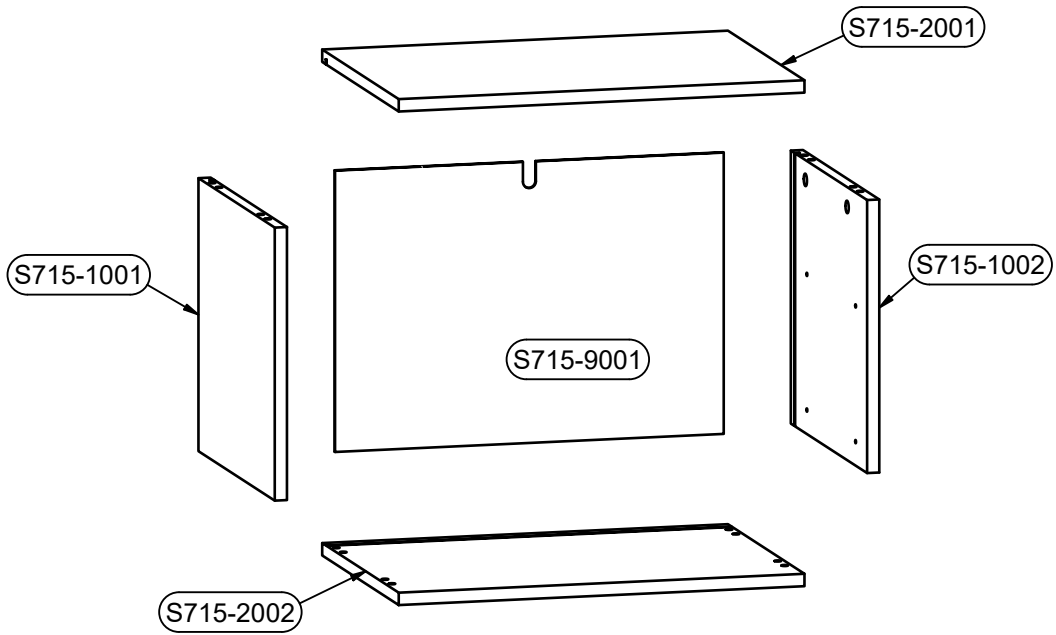

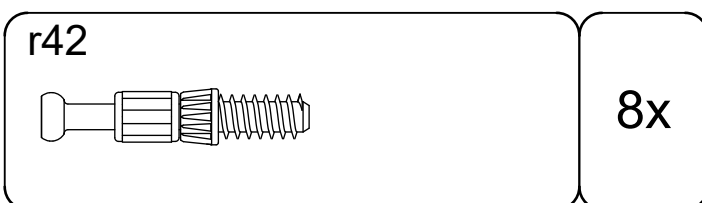

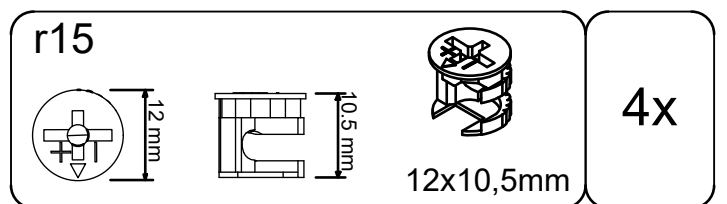
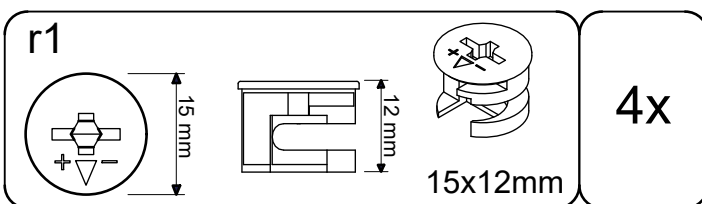
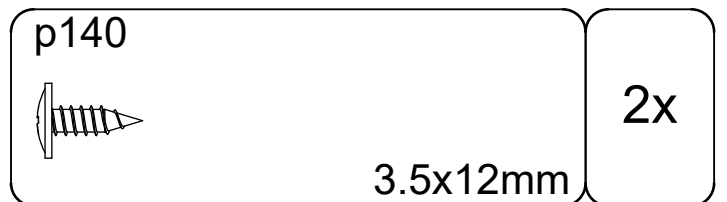
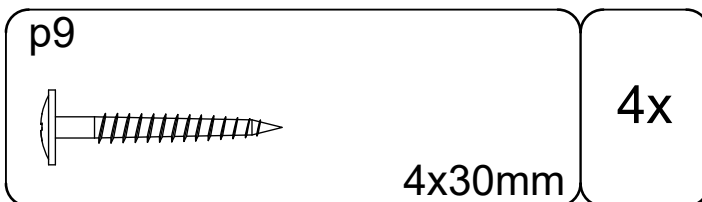
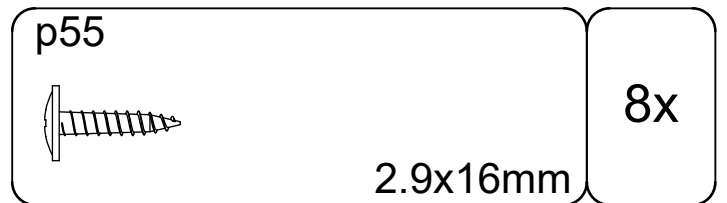
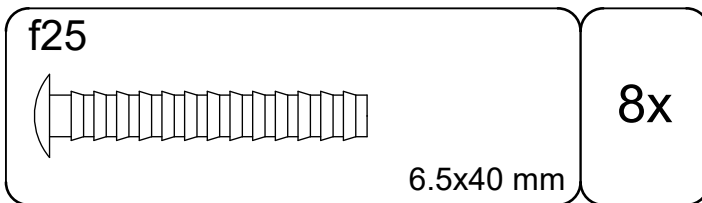
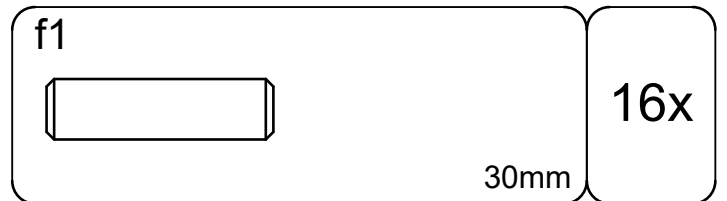
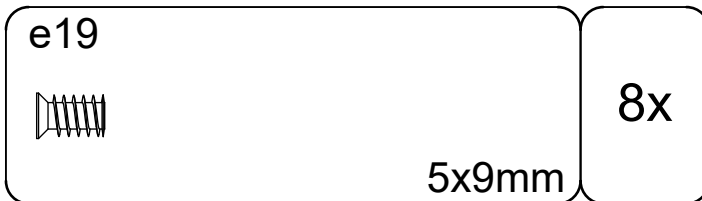
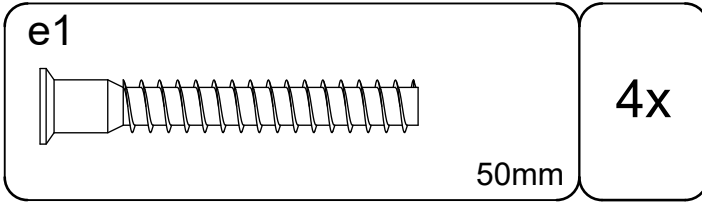
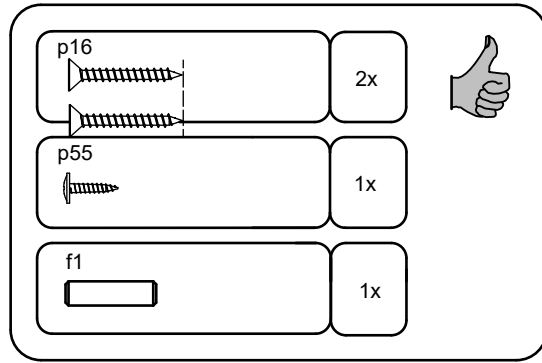
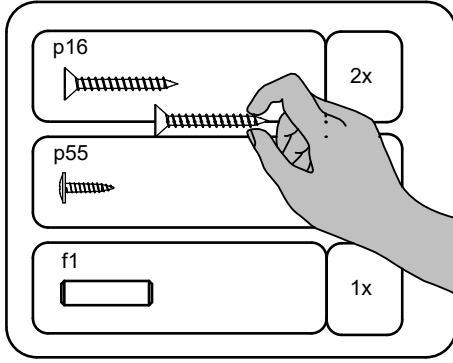

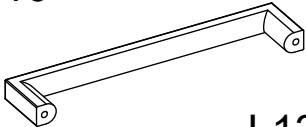
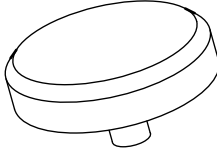
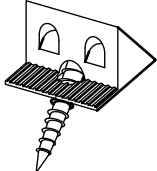
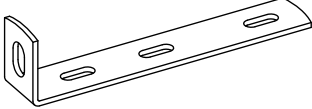
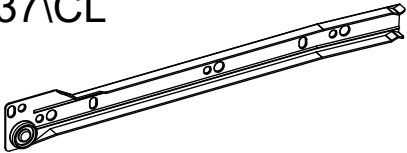
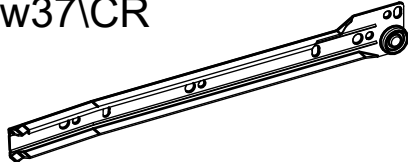
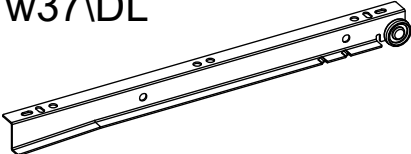
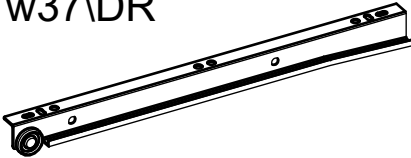
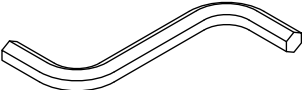
**1:1**



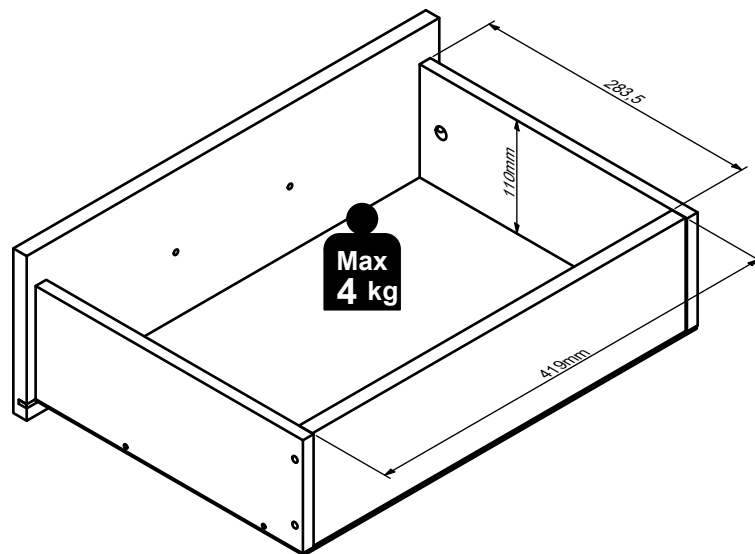
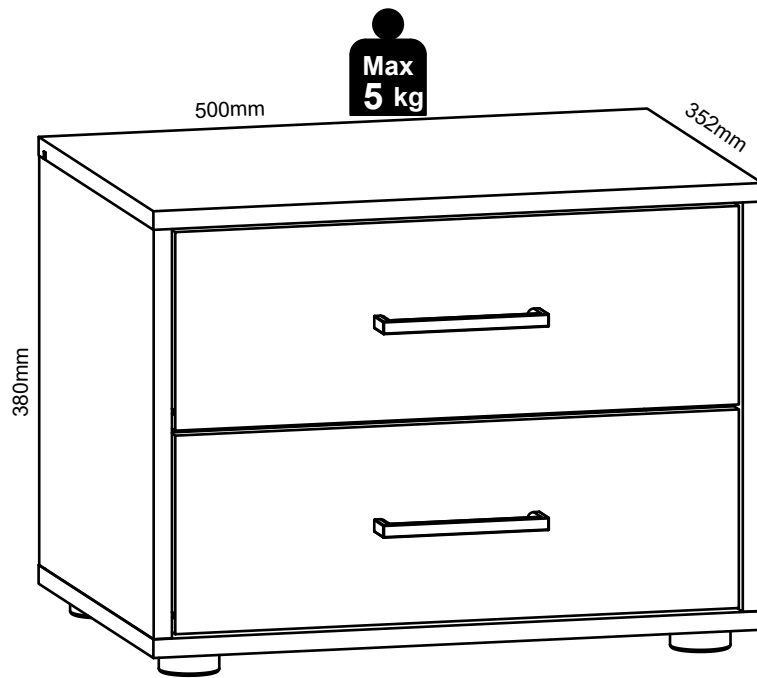

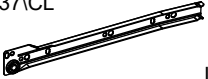

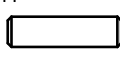
~~1:1~~

<p>c616</p>  <p>L136/128mm</p>	<p>2x</p>	<p>k27</p>  <p>fi48x20mm</p>	<p>4x</p>
<p>l2</p> 	<p>4x</p>	<p>n14\2</p> 	<p>1x</p>
<p>w37\CL</p>  <p>L300</p>	<p>2x</p>	<p>w37\CR</p>  <p>L300</p>	<p>2x</p>
<p>w37\DL</p>  <p>L300</p>	<p>2x</p>	<p>w37\DR</p>  <p>L300</p>	<p>2x</p>
<p>z1</p>  <p> 4mm</p>	<p>1x</p>		

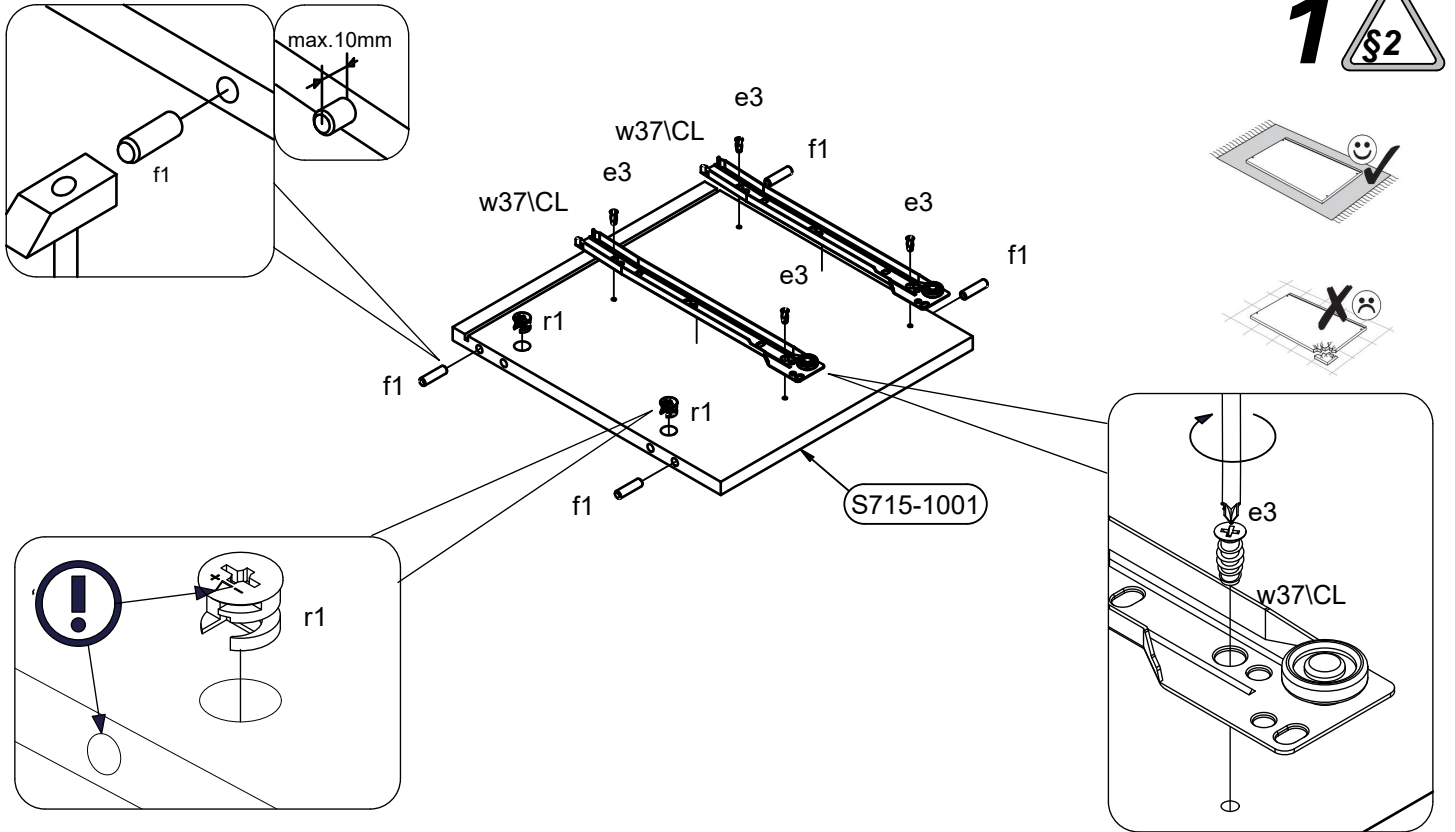

w37\CL  L300	2x	e3  6x13mm	4x	f1  30mm	4x	r1  15x12mm	2x
---	----	---	----	---	----	--	----

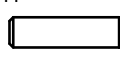

w37\CR  L300	2x	e3  6x13mm	4x	f1  30mm	4x	r1  15x12mm	2x
--	----	---	----	---	----	--	----

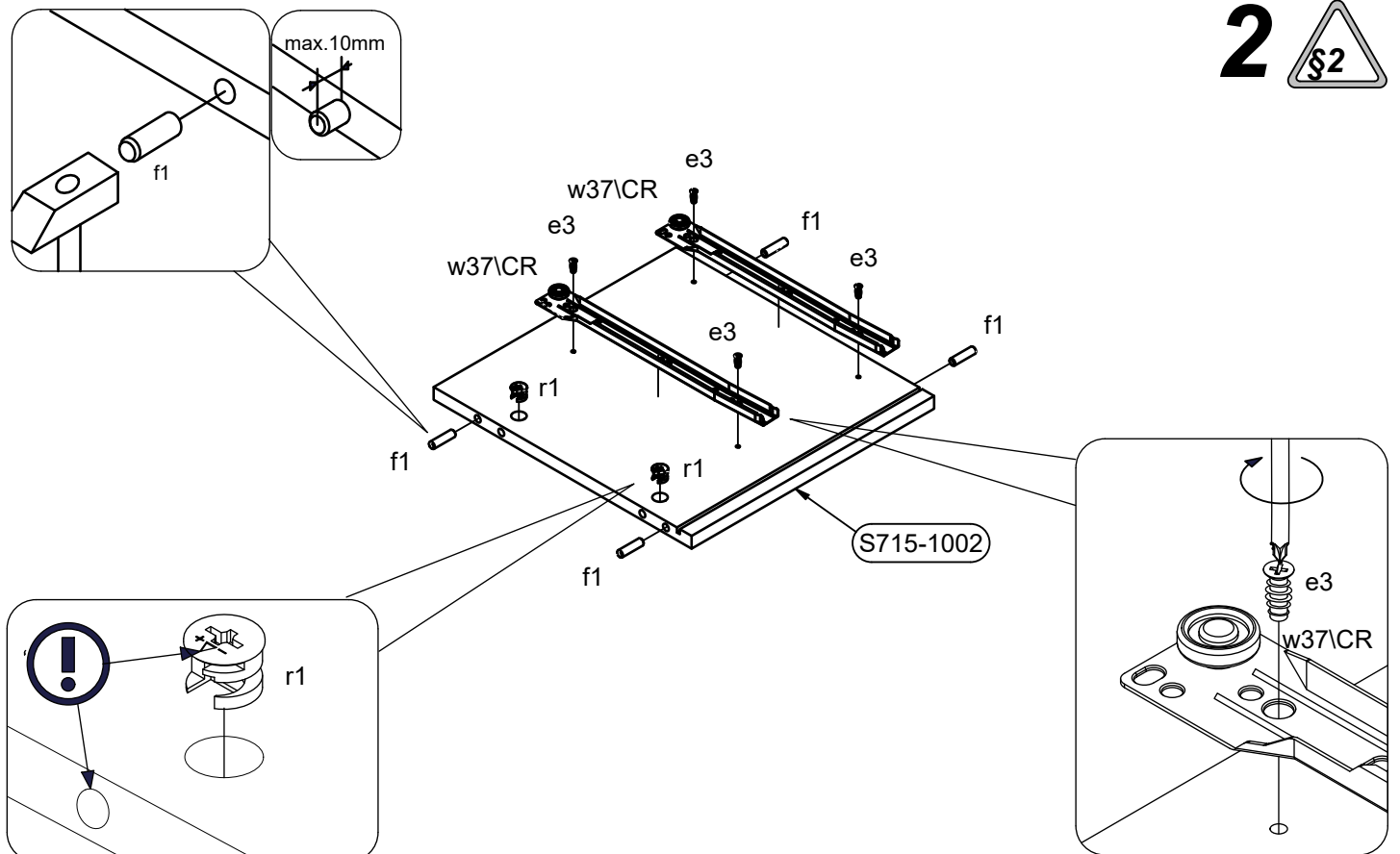

3 

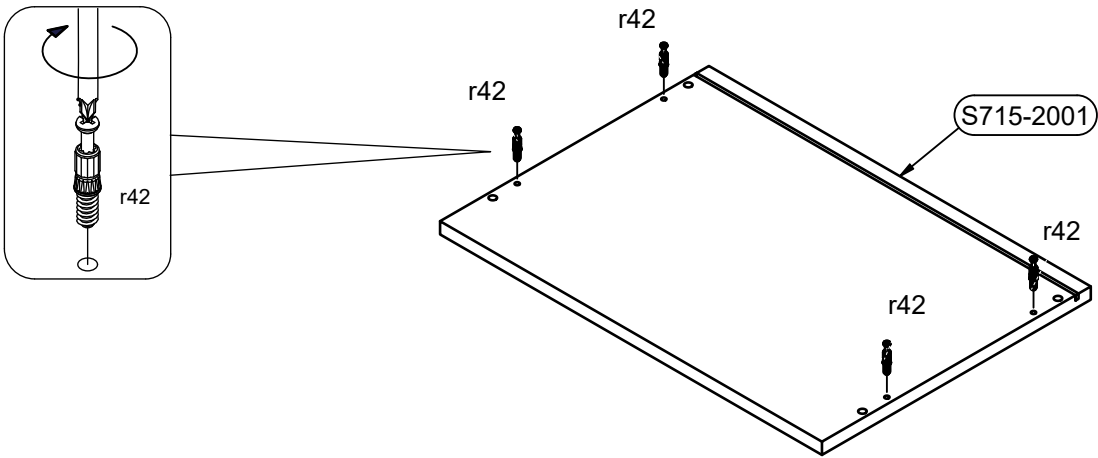
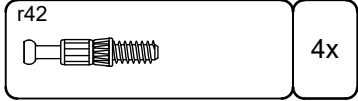

4 

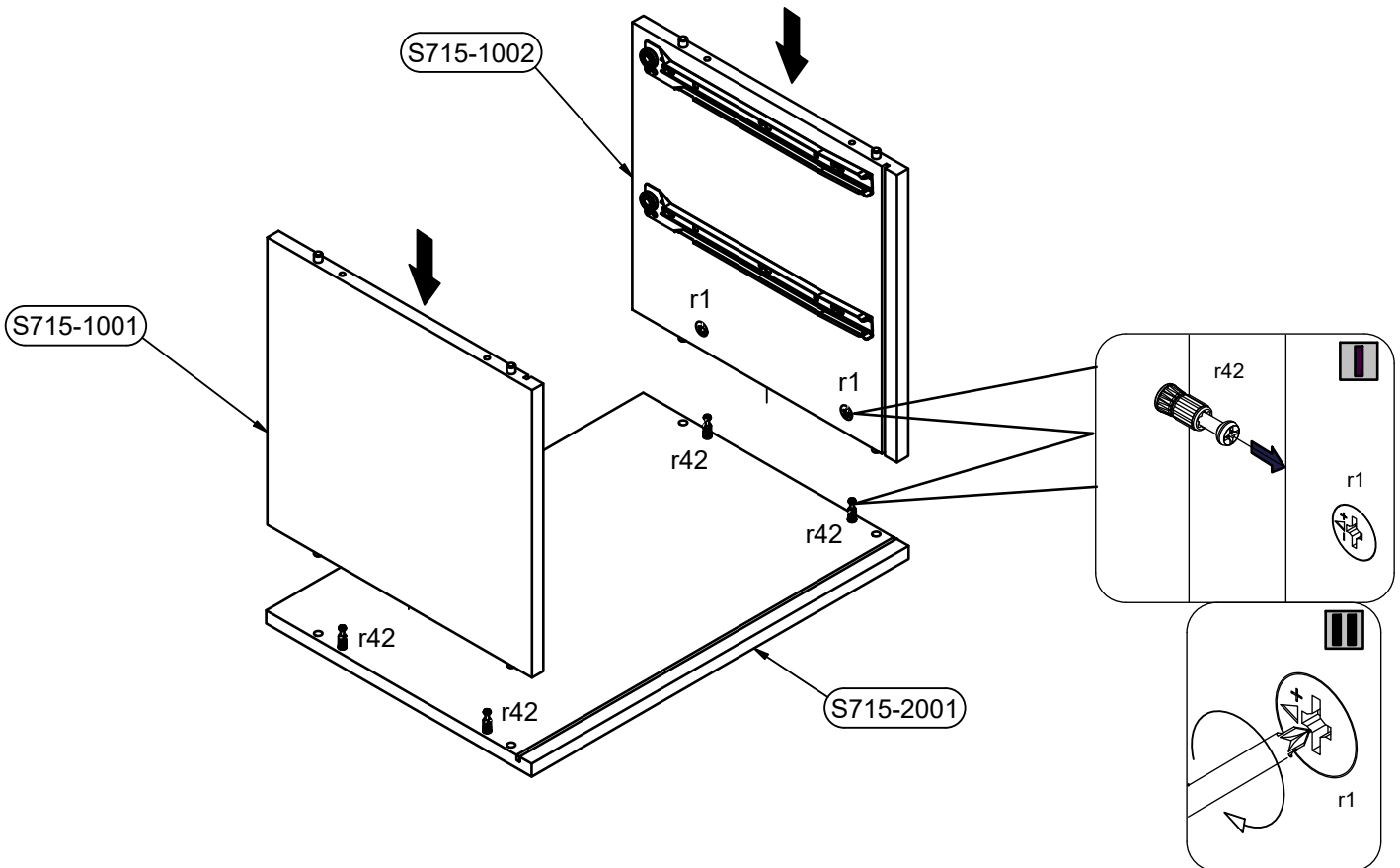

5 

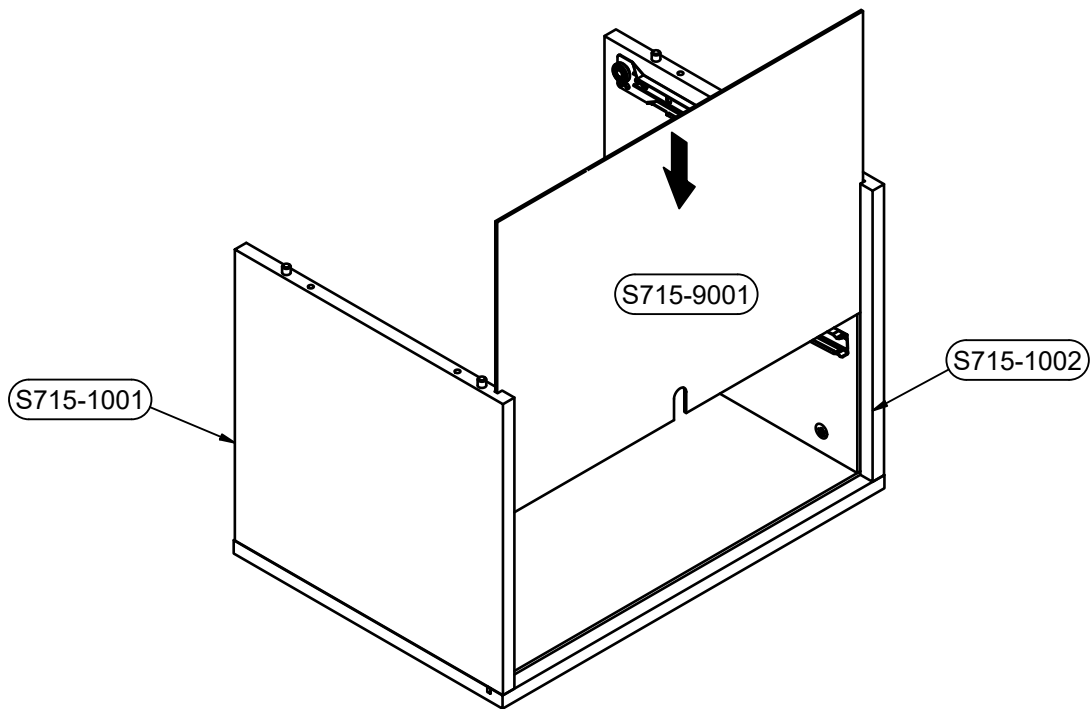

6 

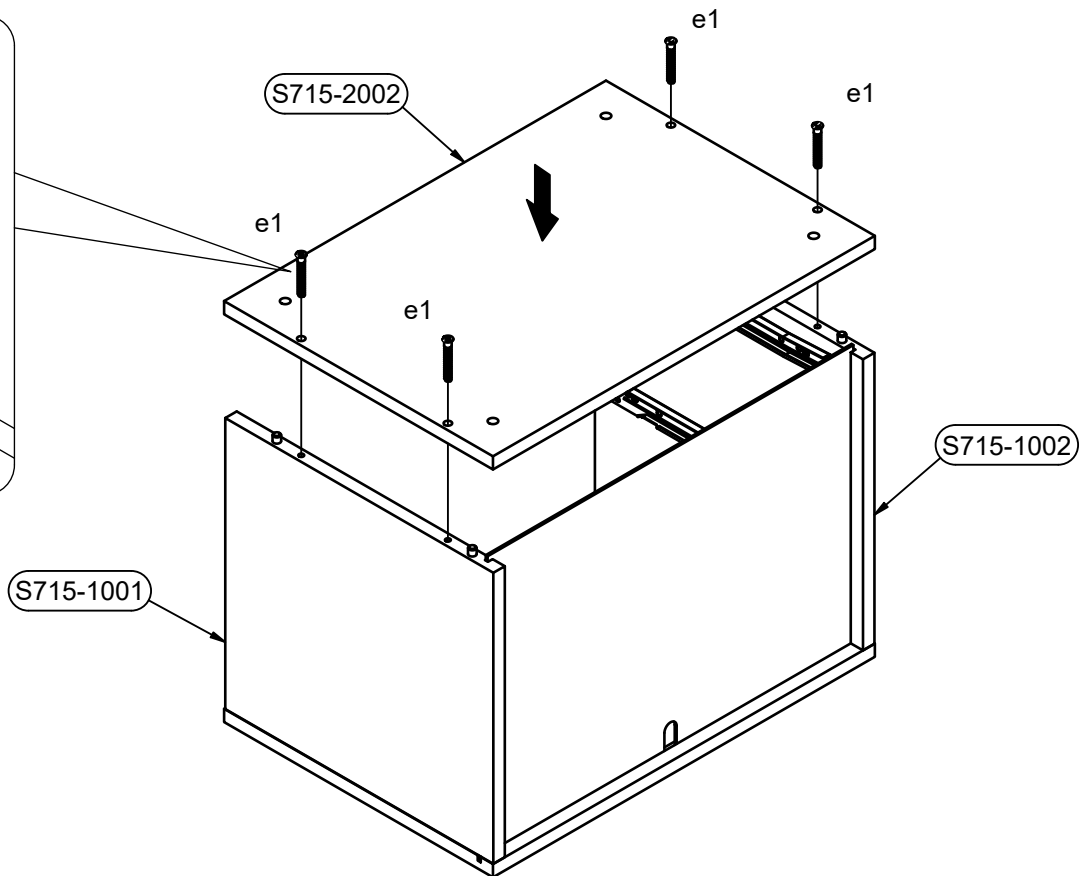
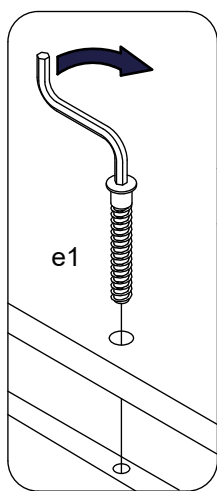
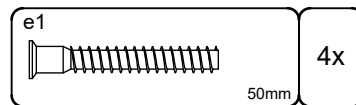

7

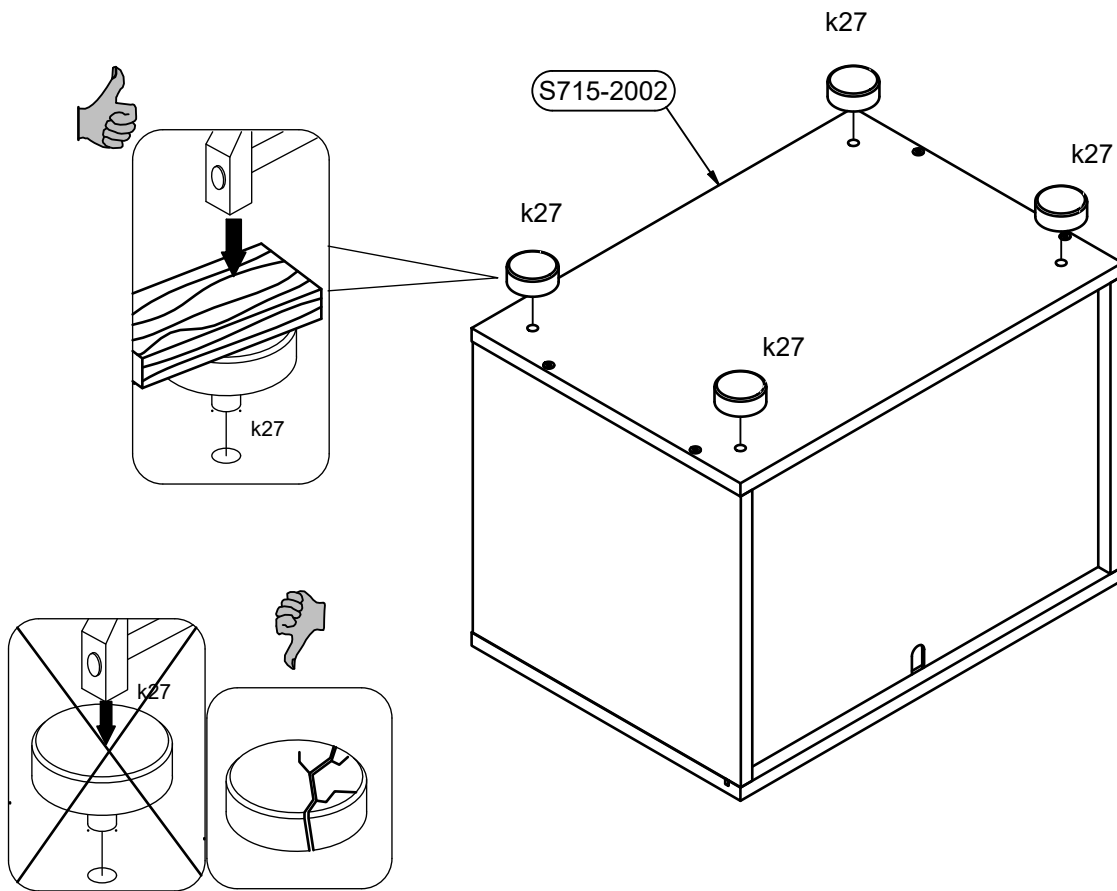
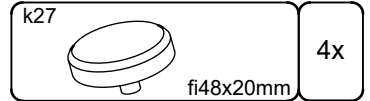

8

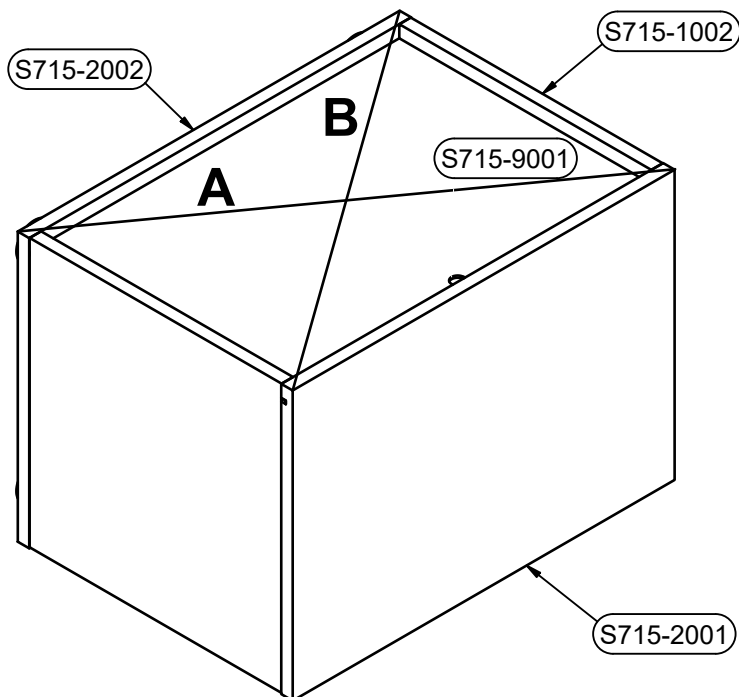

A=B  
!

# 9



	4x
---	----

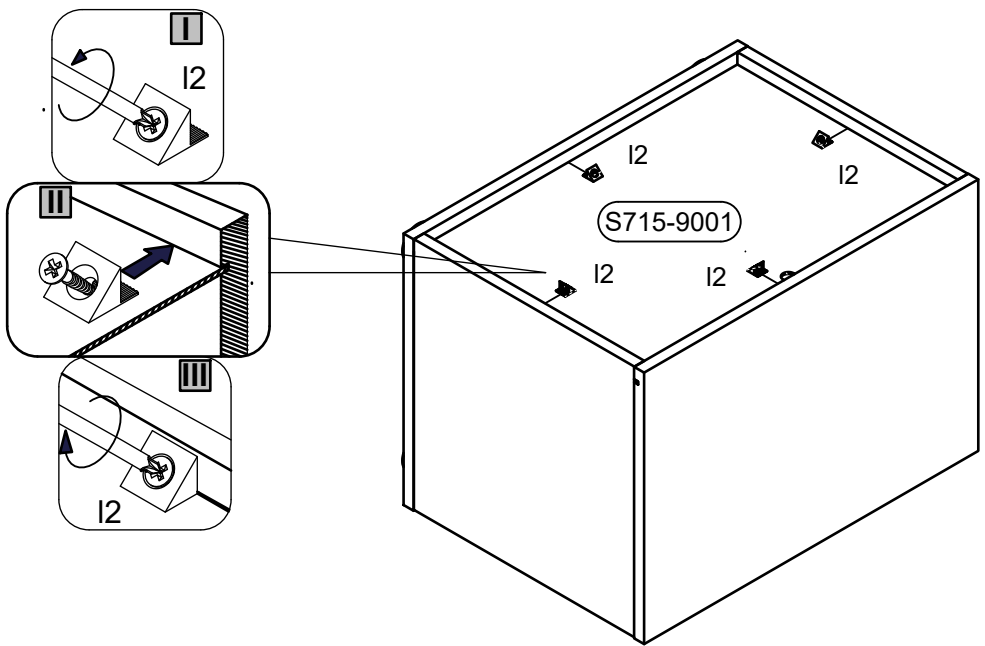

# 10



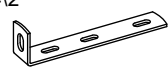

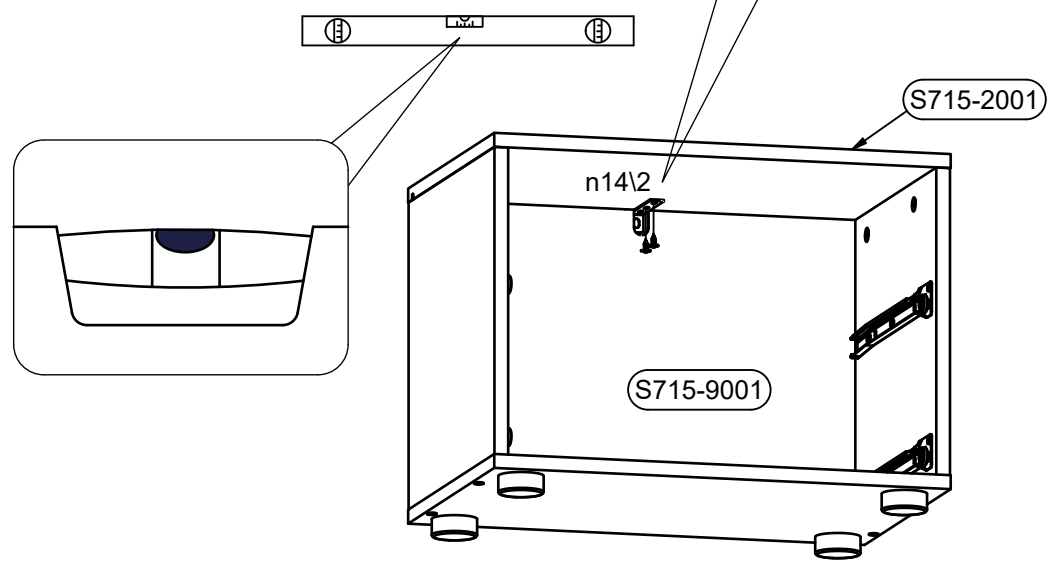
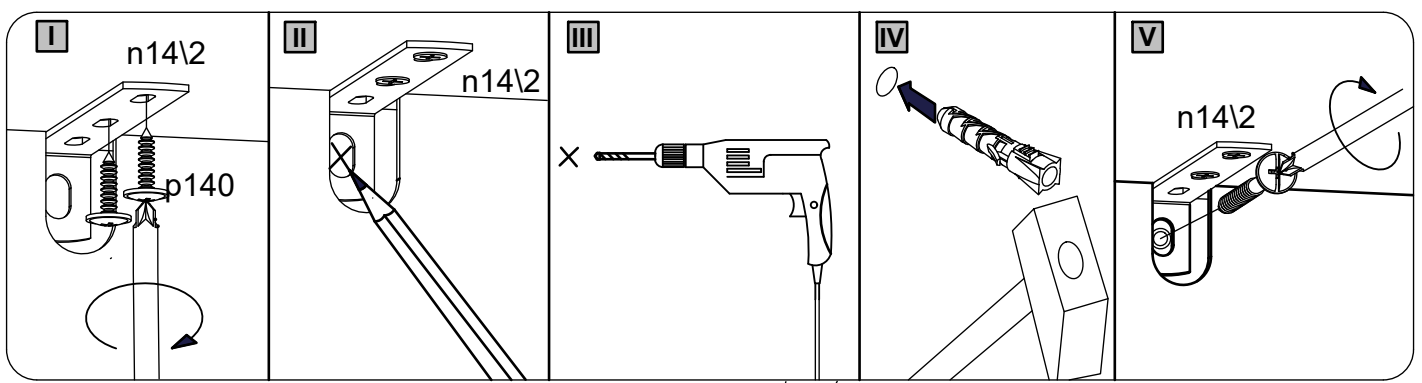
<p>p140</p>  <p>3.5x12mm</p>	2x	<p>n14\2</p> 	1x
--	----	---	----



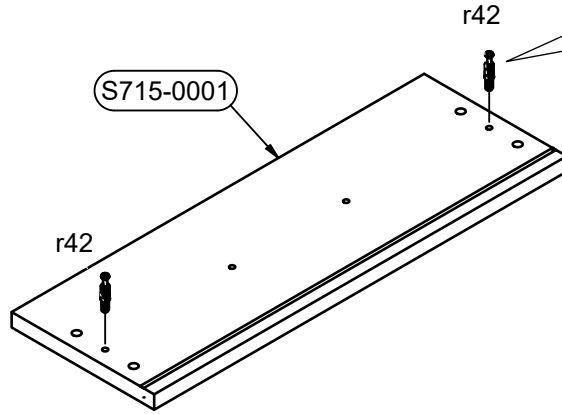
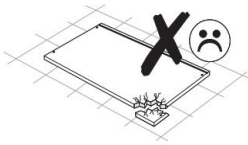
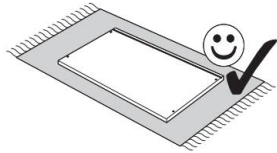

# 11

2x

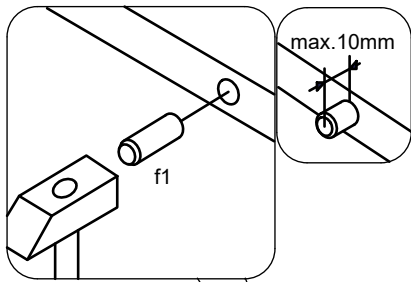
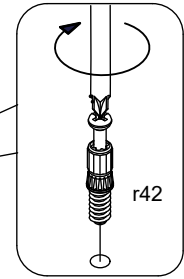

	4x
---	----

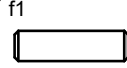

	8x		8x
6.5x40 mm		30mm	

# 12

2x

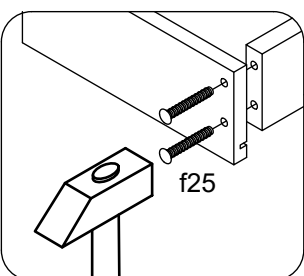
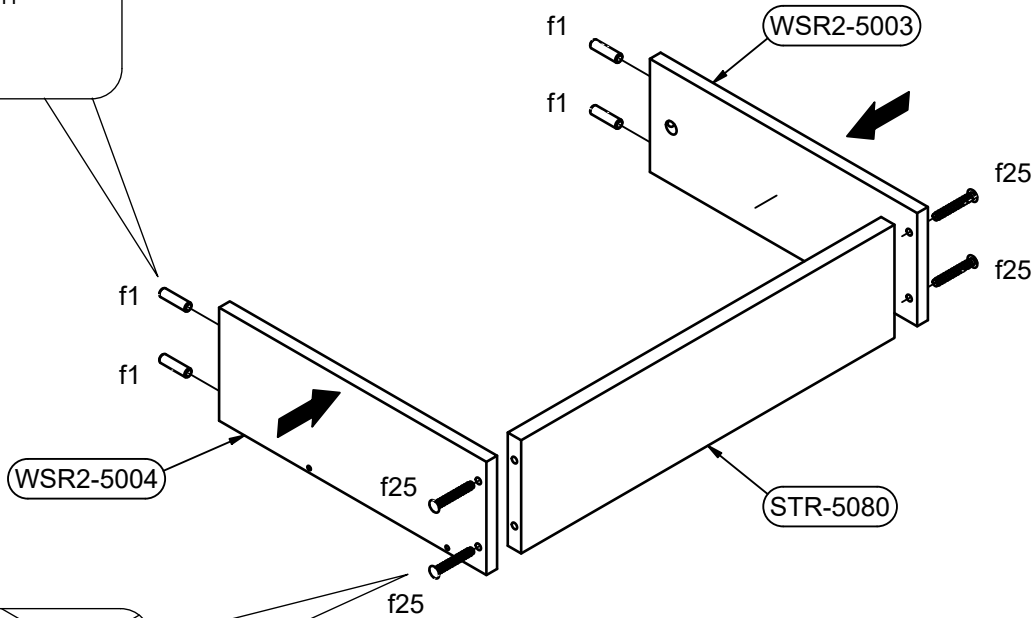

13  
2x

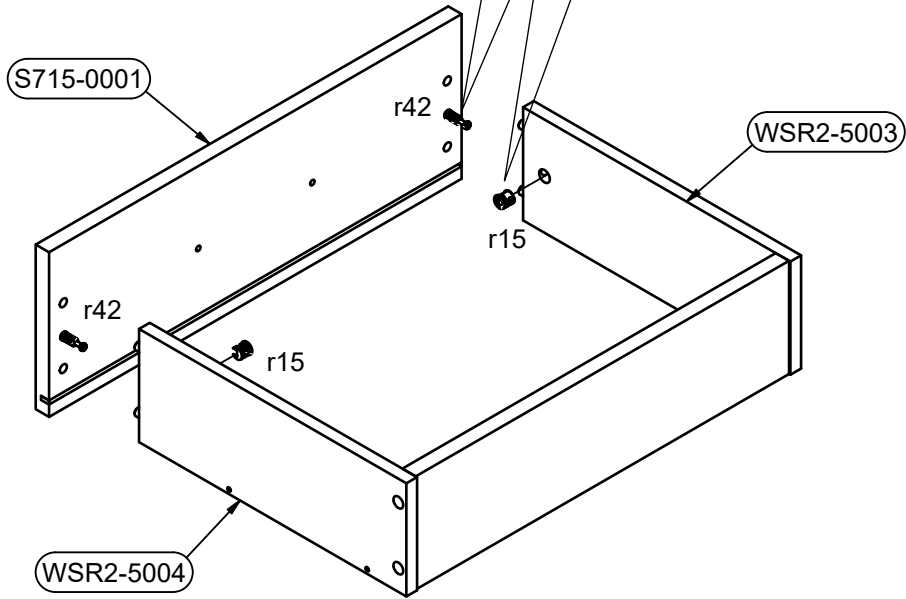
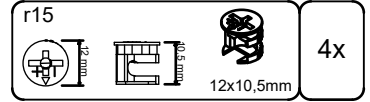
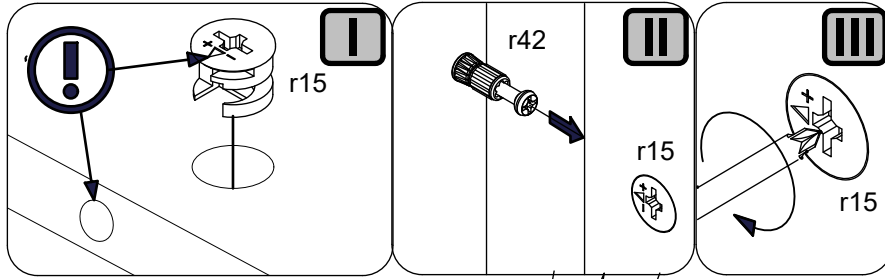

14  
2x

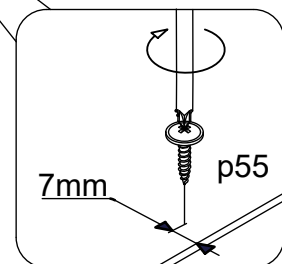
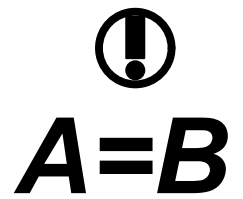
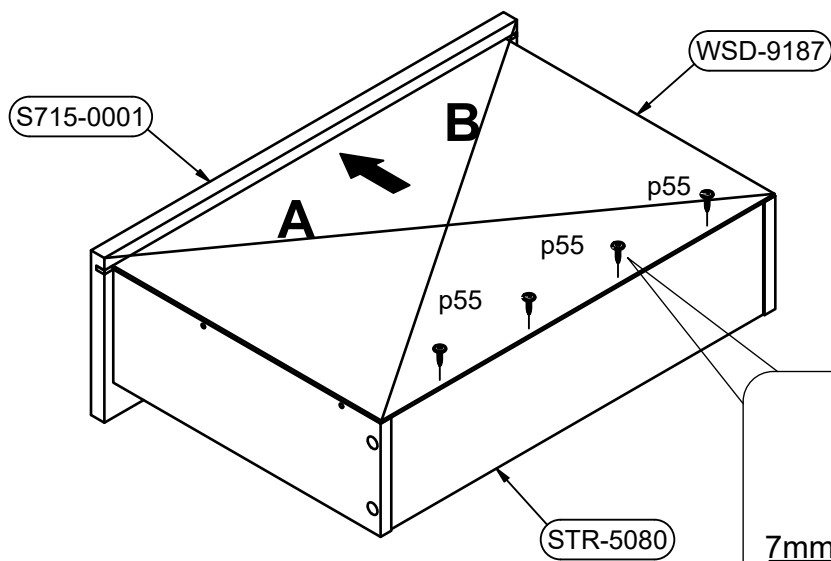
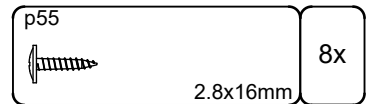

15

2x

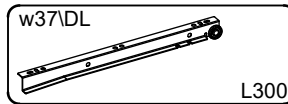

2x

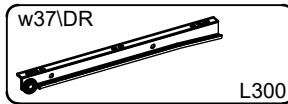

2x



8x

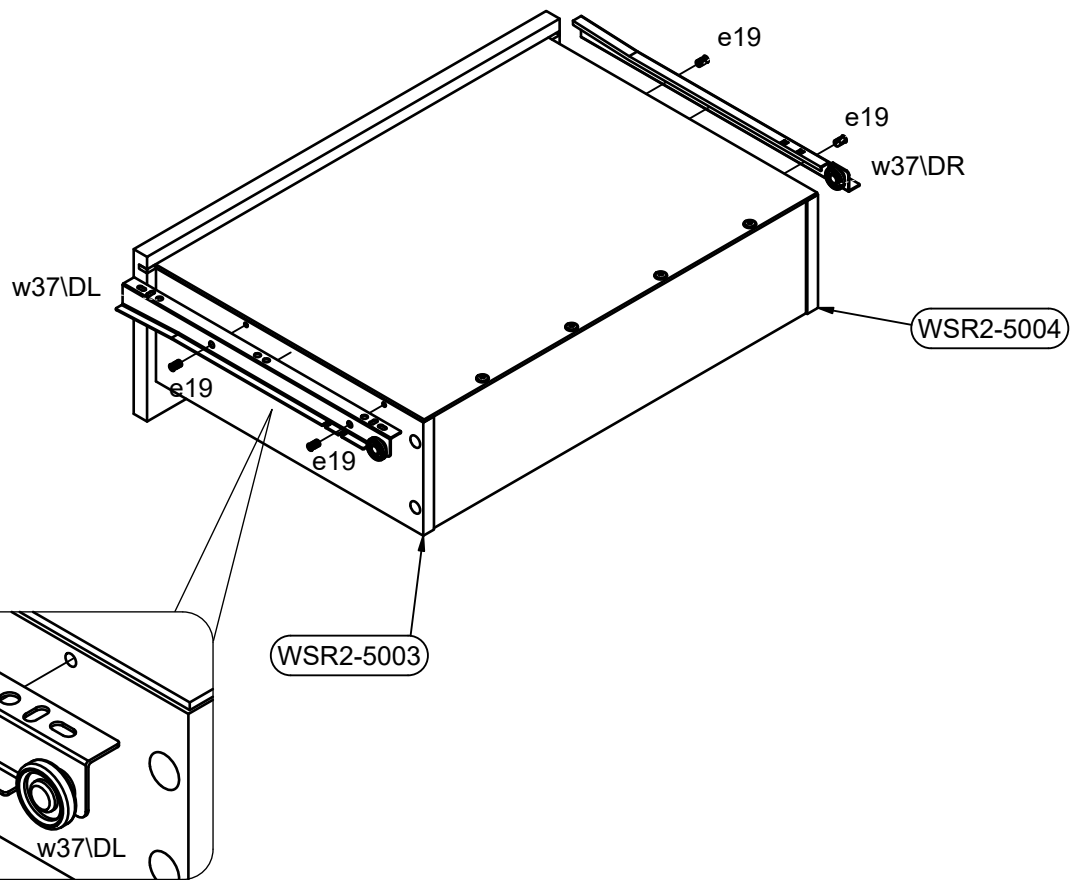

16

2x

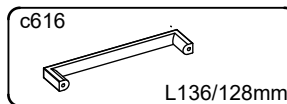

2x

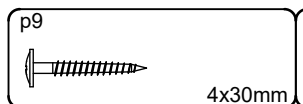

4x

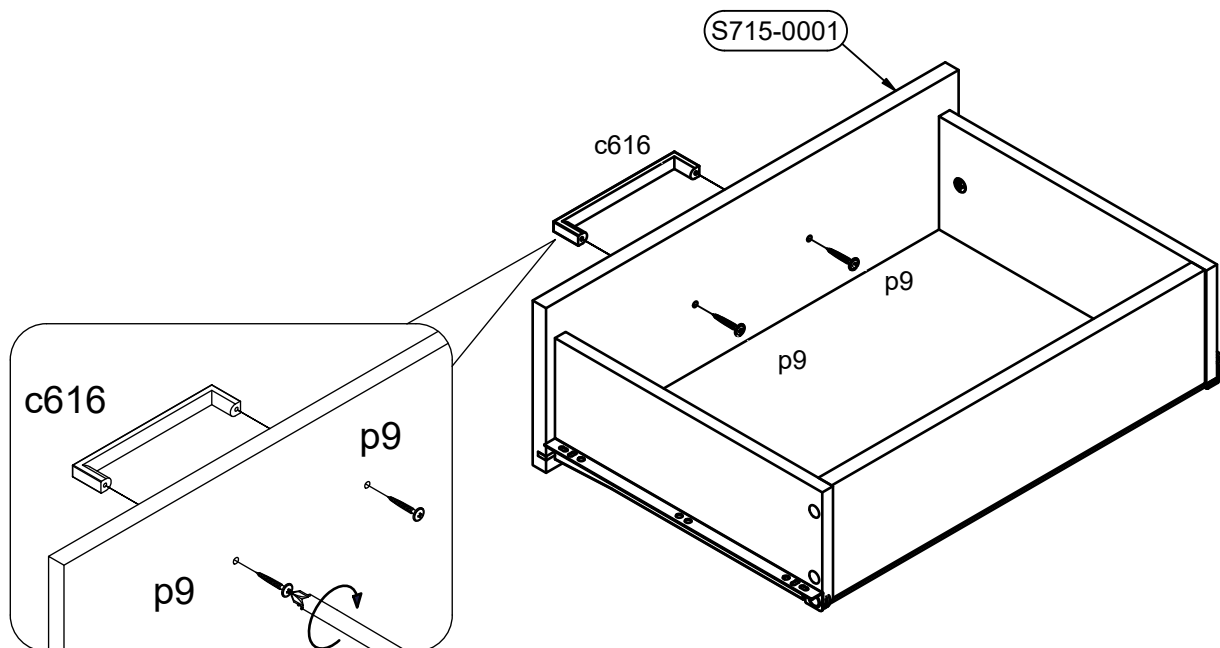

# 17

